

Inhalt

HELP FOR EPCWIN	10
Introduction	10
General	10
Terms and background information	11
First steps	11
Shortcut keys for EPCwin	18
Monogram fonts	21
Monogram special characters	22
EPCwin directory structure	23
EPCwin system limits and variables	24
Main menu	25
Main menu without design open	26
Main menu with design open	27
Select active design	30
Check design	30
Design statistics	30
Design statistics multi-head	30
Design statistics schiffli	31
Design statistics design	31
Design head	31
Design head multi-head	31
Head spacing	36
Design head schiffli	36
Color definition	41
Color table	42
Needle-color assignment	43

General Functions	43
Display	43
Scrolling	43
Zoom	44
Center design	44
View	44
Repeat view	47
Help tools	48
Help line parameter	49
Grid	50
Remarks	51
Remarks parameters	52
Measuring	52
Parameter settings	53
Parameter set	54
Parameter Program Satin stitch	54
Parameter Program Irregular divided satin stitch	58
Parameter Program Percentual Satin stitch	59
Parameter Program Systematical divided Satin stitch	60
Parameter Program Variable Satin stitch	60
Parameter Program Definable Stitch-sequences	63
Parameter Program Complex Stepstitch Fill	63
Parameter Program Curved Stepstitch Fill	68
Parameter Program Cross stitch	70
Parameter Program Object in Areas	71
Parameter Program Step-Lines	72
Parameter Program Cross boll	74
Parameter Program Chain up objects	76

Parameter Program Object on circle	77
Parameter Program Monogramming	78
Parameter Program Monogram character	80
Stitch distance ramps	82
Stencil	83
Stitch sequence	84
Parameter Stitch sequence	85
Parametersatz Design	85
Border	85
Double border	86
Bohrstäffel	88
Zugstäffel	89
Double zugstäffel	90
Zughöhl	91
Bohrhöhl	92
Wabenhöhl	93
Ziegelhöhl	94
Stoffhöhl	95
Grid filling	96
Bored hole	97
Birnenloch	98
Rectangle bored hole	99
Schneidloch	101
Cross boll	102
Steplinie	102
Selection manager needle design/standard text/head selection	102
Needle designs	103
Head selection	104

Textbaustein	106
Programmierung Sonderfunktionsanzeige	106
Punching	107
Manual punching	107
Manual stitches	108
Sonderfunktionen	108
Sonderfunktionen Multi-Head	109
Sonderfunktionen Schiffli	112
Maximum stitch length	114
Set Markings	114
Automatic programs	114
Program selection	115
Reference data input	115
Contour	116
Reference data Program Satin stitch	117
Reference data Program Stepstitch Fill	119
Reference data Program Curved Stepstich Fill	121
Reference data Program Cross Stitch	121
Reference data Program Step-Lines	122
Reference data Program Cross Boll	123
Reference data Program Chain up objects	123
Reference data Program Objects on circle	123
Reference data Program Monograming	123
Stitch direction parameters	123
Cross stitch grid parameters	124
Point/Corner/Straight Line	125
Type of selection	126
Single selection	127

Single-click selection	128
Multiple selection with rectangle	128
Multiple selection with polygon	129
Continuous selection	129
Select in block list	129
Block filter	130
Block filter multi-head	130
Block filter schiffli	131
Single action	133
Edit manual stitches	133
Edit special function	134
Edit maximum stitch length	135
Edit marker	135
Edit object stitches	135
Edit objects	136
Edit contour	137
Edit contour point	138
Edit stitch direction marker	139
Edit end point	140
Edit cross point	140
Edit drawing line	141
Edit drawing line point	142
Edit drawing object	143
Edit drawing object contour	144
Edit drawing object contour point	144
Edit-Box	145
Tool box	147
Spread	149

Numerical change	151
Suchen und Ersetzen Sonderfunktion	152
Abfrage Suchen und Ersetzen	153
Global edit	153
Global edit filter	156
Block list	156
Shift block (drag & drop)	158
Drawing	159
Stitch direction marker	160
Geometry	160
Circle	160
Arc	161
Ellipse	162
Ellipse (Angle)	162
Polygon	163
Rectangle	163
Rectangle (Angle)	164
Rectangle (R)	164
Rectangle (R) (Angle)	165
Spiral	165
Monogram TrueType fonts	166
Zeichnen Automatikprogramme	168
Zugeffekte	168
Parameter Rand	169
Double border parameters	169
Bohrstäffel parameters	169
Parameter Zugstäffel	170
Double zugstäffel parameters	171

Parameter Zughöhl	171
Filling effects	172
Bohrhöhl parameters	173
Parameter Wabenhöhl	174
Parameter Ziegelhöhl	175
Parameter Stoffhöhl	175
Grid filling parameters	176
Boring effects	177
Bored hole parameters	178
Birnenloch parameters	179
Rectangle bored hole parameters	180
Parameter Schneidloch	181
Sonstige Automatikzeichenprogramme	182
Zeichenprogramm Stichlagen	182
Cross boll parameters	183
Parameter Rapport	183
Parameter True-Type Monogramm	184
Parameter Wickellinie	185
General parameters	186
Color parameters	186
Block	186
Block management	187
Load block - Save block	188
General directory	189
General directory - Text view	190
General directory - Pictogram view	192
Convert design	193
Input / Output	193

Disk	193
Response at functions	195
Transfer EPCunix data	196
Copy EPCwin data	199
General path	201
Vector data (CMX)	202
Vector data (DXF)	203
Backup	204
Export design info	205
Scanner	207
Imaging	208
Link	210
Printing	211
Utilities	213
Default settings	214
General / Default setting	214
Depiction / Default settings	215
Editor / Default settings	217
Selection / Default setting	218
Communication / Default setting	219
Data directories / Default setting	219
System paths / Default setting	220
Language / Default setting	221
Administration / Default setting	221
Work mode / Default setting	222
Entering passwords	222
Check directory	226
Create block directory	227

Transfer system parameters from EPCunix to EPCwin	227
System check	228

Help for EPCwin

[Introduction](#)
[Main menu](#)
[Parameter settings](#)
[Punching](#)
[Editor](#)
[Drawing](#)
[Block](#)
[General directory](#)
[Input / Output](#)
[Scanner](#)
[Imaging](#)
[Print](#)
[Utilities](#)

Introduction

- [General](#)
- [First steps](#)
- [Shortcut keys](#)
- [Monogram fonts](#)
- [Monogram special characters](#)
- [EPCwin directory structure](#)
- [EPCwin system limits and variables](#)

General

Dear customer,

Congratulations on your purchase of one of the best punching systems in the embroidery industry. The EPCwin system draws on the resources of more than 20 years of experience accumulated by two embroidery software partners, namely ZSK and GiS.

User-friendliness was among the key factors that drove the development of EPCwin. You will benefit from the best possible guidance and support when drafting, drawing, punching and editing in the embroidery environment.

This manual serves the purpose of describing the system's fundamental operating procedures.

As a matter of principle we assume that you have already received training on the EPCwin system.

EPCwin offers the user context-specific help. Pressing [\[F1\]](#) in any situation takes you to the relevant page of the help manual. In dialogs, clicking [Help](#) has the same effect. If you click on [Help with EPCwin](#) in the start dialog of EPCwin, the help start page appears on the screen. From here you can access the full contents of the help manual. Where necessary, cross-references direct you to further information contained elsewhere in the help manual.

The content of the EPCwin help manual refers primarily to working with the program. It does not seek to impart special knowledge of embroidering.

Where necessary, cross-references direct you to further information contained elsewhere in the online help.

Even if you have trained on the system, you may benefit from reinforcing your knowledge by reviewing the functions offered by EPCwin with the online help.

[Terms and background information](#)

Terms and background information

Conventions used in the online help and assistant:

Text enclosed by square brackets:

Key on the keyboard, e.g. [F1] indicates the F1 key.

Text enclosed by angle brackets:

The mouse button, e.g. <Left> indicates the left mouse button and <Left><Left> indicates a double-click with the left mouse button.

If the control or shift key on the keyboard has to be pressed together with <Left>, the notation is [Ctrl] + <Left> ([Strg] + <Left> on the German keyboard) or [Shift] + <Left>. You can press either the left or the right [Ctrl]/[Shift] key, but it is essential that you hold down the relevant key on the keyboard before pressing the left mouse button.

Instead of the function keys [F1] - [F9], you can also use the number keys on the number keypad. In this case, the number lock must be engaged first (the Num LED must be lit).

You can enter decimal points (e.g. 3.4) with the decimal point key on an English number keypad (decimal comma with the comma key on the German number keypad).

Some dialogs allow actions to be triggered directly by shortcut keys; entering a number executes the function without requiring an on-screen button to be pressed with the input device. The relevant number is indicated before the symbol or button on the screen. The input box for the shortcut is active as soon as the dialog is called. Clicking a different function (symbol, on-screen button etc.) deactivates the shortcut. It is reactivated by clicking the shortcut input box.

First steps

From the working copy to the finished design

Creating an embroidered design on the basis of an original image involves several fundamental steps:

- Scan image
- Complete design head and save image
- Load design with image
- Enter dimension system
- Retrace outlines
- Create reference data
- Save design
- Output stitch data

These items comprise only a selection of the options provided by the EPCwin software. Only the essential work stages are described here.

After installing the software and **Entering passwords**, the user is presented with the EPCwin system in a condition that is ready to operate. The following steps can be performed only if you have not edited the default settings.

Screen structure in menu mode

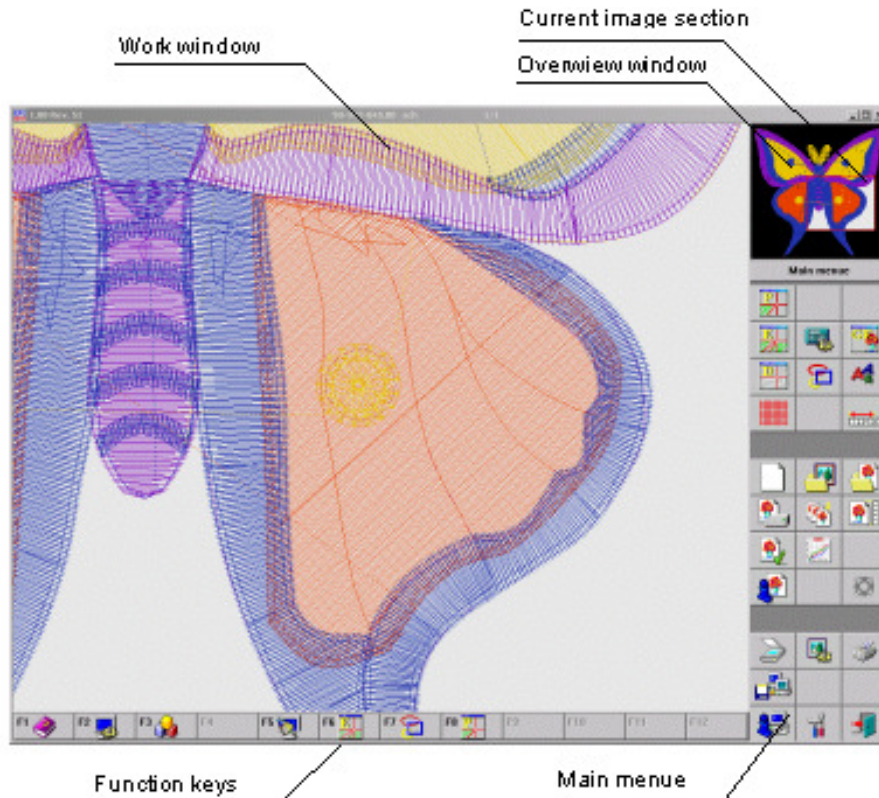

Scan image



Press button <Left> on the scanner symbol to initiate the scanning operation. A list of image reading devices (scanners, cameras) appears on the screen. Select one of the options (e.g. with *Select*). This dialog and the ensuing scan program do not form part of the EPCwin software. Follow the instructions issued by the scan program. The program will probably contain a button inscribed *Send to application* or similar.

Further information on scanning in EPCwin is contained under [Scanner](#).

Complete design head and save image



Once the scanned image data have been transferred to EPCwin, the screen issues instructions for entering the design head data. The mask already contains some essential information, including the design number that unmistakably identifies the design. The number is issued automatically and preset. When you subsequently select an image in the general directory, you will see not only the design number, but also the design name, customer and group. These items are not preset in the design head mask. Entering data in the design head boxes achieves a clearer structure for subsequent work. For further information see [Design head](#).

Load design with image



Press <Left> on the symbol to open the general directory. From here you can select the new design containing the scanned image by way of the design number or name, name of the customer, or group (with <Left> in the relevant line); confirm with *OK*. The design with the image appears in the working window. Since no other design data exist at present, the display shows only the image.

For further information see [General directory](#)

Enter dimension system



When a design is open, a red drawing cross or reticle appears on the screen as well.

The assistant asks you to enter a dimension system. The system is determined by entering two points and a length. Use <Left> twice in succession to specify two prominent points in the image. The dialog that follows asks you to state the desired distance between the two points. Confirm the dimension with *OK*.

For further information on the dimension system see [Main menu with design open](#).

Retrace outlines



Layout of assistant bar in drawing mode

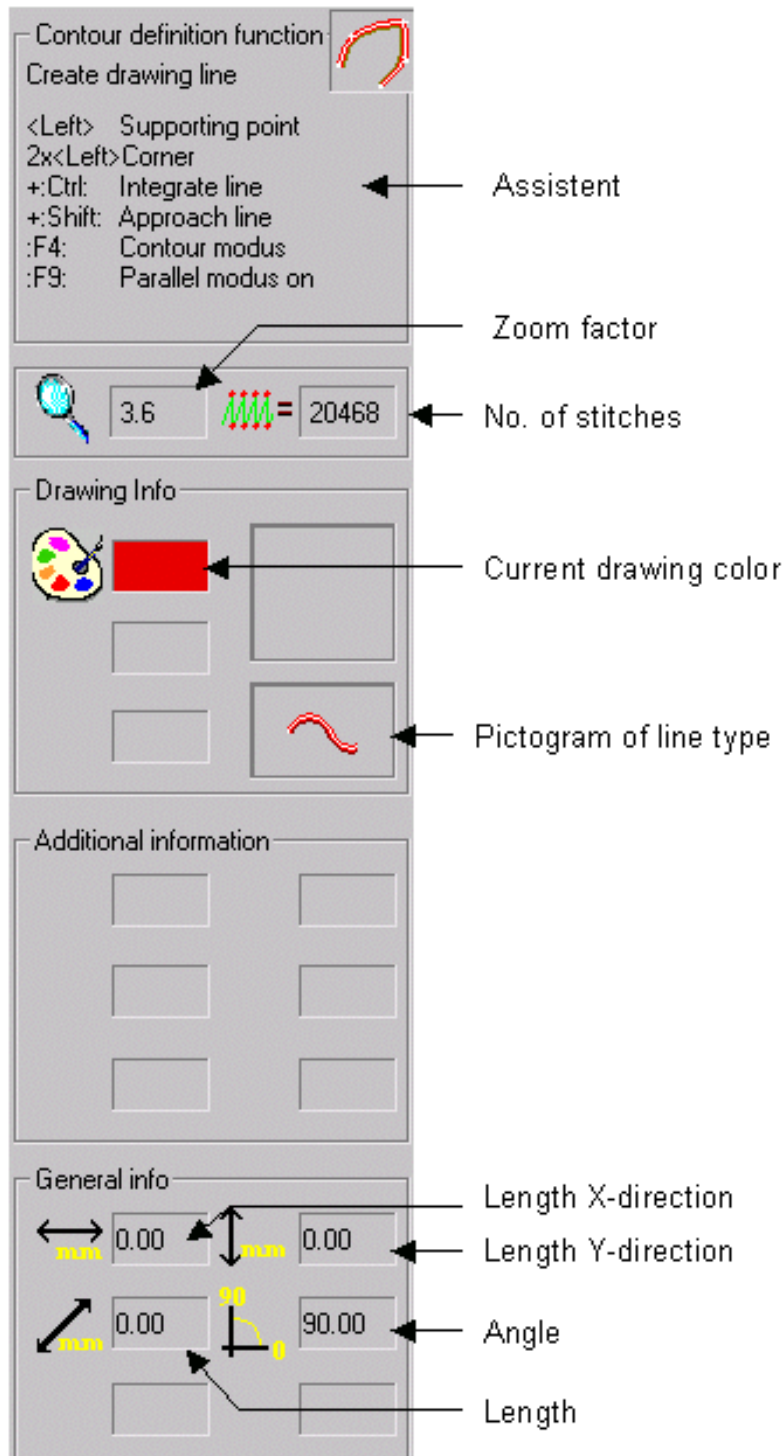

Press <Left> on this symbol to start the input of the drawing data. You are now in the drawing mode.

Retrace the outlines of the image; these drawing data will form the basis of the outlines in the embroidered design.

Exit the drawing mode with [Esc]; this takes you back to the main menu.

For further information on drawing see [Drawing](#).

Create reference data



Layout of assistant bar in punch mode

The screenshot shows the 'Punching' panel in the EPCwin2.5 software. The panel is organized into several sections:

- Manual punching:** Contains a small icon with a yellow 'D' and a red cross. Below it, the following settings are listed:
 - <Left> Manual stitch
 - + :Ctrl: Manual jump stitch
 - :Div.: Block marker
 - :x: Max. stitch length
 - :F12: Special functions
- Zoom factor:** A magnifying glass icon is next to a text box containing the value '3.6'. To its right, a small diagram shows a red zigzag line with the text '= 20468'.
- Program info:** Contains a 'PRG' label next to a text box with '1.1'. Below it is a small diagram of a zigzag line with the value '5.00'. To the right is a large blue pictogram of a leaf-like shape.
- Punching status:** Contains several indicators:
 - A needle icon next to a text box with '3' and a yellow square.
 - A green zigzag line icon next to a text box with '127'.
 - A yellow 'SF' label next to a needle icon.
 - A green upward arrow icon next to a needle icon.
- General info:** Contains four text boxes with numerical values:
 - 50.90 (with a horizontal double-headed arrow icon)
 - 2.62 (with a vertical double-headed arrow icon)
 - 50.96 (with a diagonal double-headed arrow icon)
 - 357.06 (with a circular arrow icon)

Labels on the right side of the image point to these elements:

- Assistent (points to the manual punching section)
- Zoom factor (points to the magnifying glass icon)
- No. of stitches (points to the '= 20468' text)
- Current program (points to the 'PRG 1.1' text)
- Pictogram of program (points to the blue leaf pictogram)
- Distance (points to the '5.00' text)
- Current needle color (points to the yellow square)
- Current max. stitch length (points to the '127' text)
- Jump stitch automatic on (points to the green upward arrow icon)
- Working mode: stitches (points to the 'SF' label)
- Stitch length: X-direction (points to the '50.90' text)
- Stitch length: Y-direction (points to the '-2.62' text)
- Stitch angle (points to the '357.06' text)
- Stitch length (points to the '50.96' text)

Press <Left> on this symbol to start the input of the stitches and reference data. You are now in the punching mode. Here you can both enter stitches manually and create objects containing automatically calculated stitches. Exit this mode with [Esc]; this takes you back to the main menu.

For further information on punching see [Punching](#).

Save design



Pressing <Left> on this symbol starts the *Save design* operation; it takes you back to the design head dialog.

If you do not change the design number, the existing design data are overwritten. If you wish to create

a new design, allocate a new design number (with <Left> on *Design number*).
Press *OK* to trigger the save operation.
For further information see [Design head](#).

Output stitch data



Press <Left> on this symbol to start the output of the stitch data. Select *Disk* in the mask; another on-screen dialog appears. Select the desired machine type and disk format, e.g. *ZSK TC* and *DOS*. Use *Write* to obtain the general directory. Select the design whose data you wish to output. Confirm with *OK*; the design is written to the disk.

For further information on Input / Output, see [Input / Output](#).

General remarks

Functions of [Esc]

- Aborts current action (e.g. moving a stitch)
- Selects a different mode (e.g. switches from editor back to punch)
- Aborts a dialog (without changing modes)

How do I reach the main menu?

The program opens with the main menu. If you are working elsewhere in the program, press [Esc] repeatedly until the main menu appears on the right. Exception: If you are participating in an on-screen dialog (e.g. deciding whether you wish to save an edited design), pressing [Esc] or *Cancel* does not take you out of the current part of the program, so that you can still trigger the desired action.

How do I reach the main editor?



Layout of assistant bar in edit mode



Main editor

Single selection 

<Left> Select
 +:Ctrl: Multiple selection
 +:Shift: Stitch area
 :Return: Edit red marked stitch
 :0: edit object

Assistent

Zoom factor



3.6   = 20468
 No. of stitches

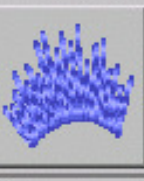

Program info



PRG 2.1 
 Pictogram of program

 4.30
 Distance

Punching status

 1 
 Current needle color

 127 
 Current max. stitch length

SF  
 Jump stitch automatic on

Working mode: stitches

16:	-28/	0 #
17:	-28/	0 #
18:	42/	0 #
19:	31/	0 #
20:	31/	-1 #
21:	32/	-1 #
22:	-28/	0 #

Current stitch

Stitch length Y-direction $\frac{1}{10}$ mm

Stitch length X-direction $\frac{1}{10}$ mm

Stitch number

Precondition: A design has to be open.

Once a design is open, press [F6] or <Left> on this symbol to reach the main editor.

If you are currently working in a different editor (e.g. the object editor), press [Esc] (repeatedly if necessary) to return to the main editor.

How do I open a new design?

Precondition: You must be working in the main menu.



Press <Left> on this symbol to create a new design.

How do I open an existing design?

Precondition: You must be working in the main menu.



Press <Left> on this symbol to open an existing design; a general directory containing a list of existing designs appears (in plain text or in the form of pictograms). Select a design with <Left><Left>.

How do I edit a design?

Precondition: A design has to be open and you must be working in the main editor.

The default setting in the main editor is single selection.

To edit a single element (lines and points of a design, contour, stitches), select it with <Left>. You can then perform single actions with this element (see [Single action](#)).

If you wish to edit several elements, press [F3] to obtain the on-screen dialog [Type of selection](#). One of the options available for selection here is [Rectangle](#). Creating a rectangle gives you access to the [Edit box](#). The edit box is a tool that applies actions to each individual element that it contains (e.g. move).

How do I create an object?

Precondition: You must be working in the punching mode (manual punching).

Pressing [F11] opens the dialog [Program selection](#), in which you can select an automatic program. Depending on the program you select, the assistant window contains a series of instructions for creating the elements that make up the desired object.

Example:

You select Satin Stitch No. 1 program. The text displayed by the assistant instructs you to enter the first outline. Once you have made the relevant input, the assistant instructs you to enter the second outline. You are then asked to enter the stitch direction markers. Once you have completed this task, the assistant instructs you to enter an end point. Once the end point is entered, the object is calculated automatically.

Shortcut keys for EPCwin

General assignment

The keys marked * are on the number keypad of the keyboard. Make sure that [NumLock](#) is switched on.

The following keys are available at all levels:

[F1]	Context-specific help
[F2]	View
[-] *	Start zoom function
[Page up]	Enlarge zoom by fixed increment
[Page down]	Reduce zoom by fixed increment
	(set the value under Default Settings)
[Space bar]	Move window
[C]	Zoom design to screen size
[M]	Measuring
[H]	Help tools

[Q] Abort drawing operation

Main menu

Key assignments when a design is open:

[F3] Start Editor with block function
 [F5] Redraw
 [F6] Point/Corner/Straight Line
 [Cursor keys] Manual scrolling

Punching

<Left> Insert stitches
[Ctrl] + <Left> **Insert jump stitches**

[F3] Start Editor with block function
 [F6] Call Editor
 [F8] Call drawing function
[F10] [0]* [Enter] **Start an object with the current program type**
[F11] [+]* **Select program type**
[F12] [,]* **Insert special function**
[Div]* **Insert block marker**
[*]* **Maximum stitch length**
[Backspace] [Delete] **Delete previous stitch**
[L] **Load block from Block Manager**
 [Ctrl] + [S] Save design
 [Ctrl] + [V] Load block from clipboard

Contour

<Left> Enter reference point
[Ctrl] + <Left> **Integrate existing contour**
[Shift] + <Left> **Approach existing contour or grid**
 [Ctrl] + [K] see [Ctrl] + <Left> (for assignment of digitizer mouse buttons)
 [Ctrl] + [J] see [Shift] + <Left> (for assignment of digitizer mouse buttons) [Z] [T]
 [U]

[Z] [T] [U] Automatically create reference points by tracing

[F4] Change input mode: Point/Corner/Straight Line

[F9] Change input mode:

Point/Corner/Straight Line

<Left> Select
[Ctrl] + <Left> **Multiple selection**
[Shift] + <Left> **Determine stitch section**

[Home] **Jump to start of design**

[End] **Jump to end of design**

[Alt] [F]	Toggle to and from block list
[Cursor keys]	Run through design stitch by stitch (see also Default Settings)
[Shift] + [Cursor keys]	Determine stitch section
[F3]	Determine type of selection
[F4]	Gray/color toggle
[F5]	Redraw
[F6]	Select/deselect filter
[F7]	Edit filter setting
[F8]	Large/small stitch list
[F9]	Stitch section: run front/back

If a stitch is preselected:

[F12] [,]*	Edit special functions
[Div]*	Edit block marker
[*]*	Edit maximum stitch length
[Insert]	Select punch insert mode
[Delete] [Backspace]	Delete stitch

Object Editor

[F3]	Convert object, e.g. to manual stitches
[F5]	Redraw
[F6] [Insert]	Insert
[Delete]	Delete object
[F7]	Enter stitch distance
[F8]	Edit parameter set

Edit-Box

<Left>	With mouse button pressed: move inside box
<Left>	Click in box: switch box markers
<Left>	Click on box markers => change size / rotate / distort

[F2]	Copy block
[F3]	Save block
[F4]	Call ToolBox
[F10]	Change selection
[F11]	Numerical input
[F12]	Edit line colors

[Ctrl] + [C]	Copy block to clipboard
--------------	-------------------------

Design

[F3]	Start Editor with block function
[F6]	Call Editor

[F8]	Call punch function
[F12] [,]*	Select line color
[Backspace] [Delete]	Delete previous reference point (operates only if the line has not yet been concluded with [Return])
[Insert]	Reinsert most recently deleted reference point
[L]	Load block from Block Manager
[Ctrl] + [S]	Save design
[Ctrl] + [V]	Load block from clipboard

Monogram fonts for program 33

The following fonts are supplied together with EPCwin:

NimbusBold 6mm

NimbusBold 10mm

NimbusBold 22mm

FuturaMedium 6mm

Futura Medium 10mm

Futura Medium 22mm

Nimbus Condens 6mm

Nimbus Condens 10mm

Nimbus Condens 22mm

Euro Heavy 6mm

Euro Heavy 10mm

Euro Heavy 22mm

Walbaum TMed 6mm

Walbaum TMed 10mm
Walbaum TMed 22mm

Fritz Quadrata 6mm
Fritz Quadrata 10mm
Fritz Quadrata 22mm

Engl Schreib 6mm
Engl Schreib 10mm
Engl Schreib 22mm

Monogram special characters

To use a special character in the monogram fonts, press and hold down **[Alt]** and enter the numeric code contained in the table on the number keypad. This table is valid only for the German keyboard. The table applies only to Code Page 850 MS-DOS Latin 1.

ALT+		ALT+	
128	Ç	157	Ø
129	ü	164	ñ
132	ä	165	Ñ
134	à	168	ı
135	ç	173	ı
137	ê	174	«
139	ï	175	»
142	Ä	189	¢
143	Å	208	ð
145	æ	209	Ð
146	Æ	211	Ë
148	ö	216	Ï
153	Ö	225	ß
154	Ü	236	ý
155	ø	237	Ý
156	£	245	§

EPCwin directory structure

System

e.g. C:\Program Files\...

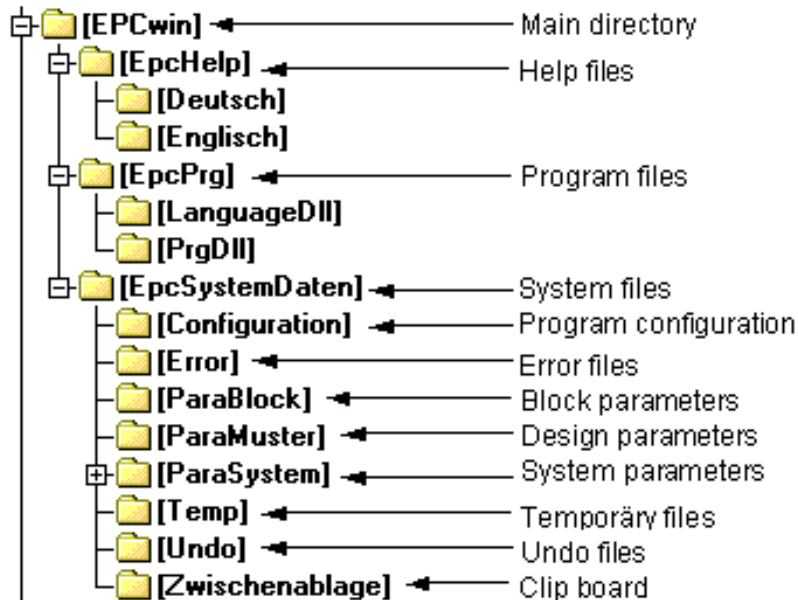

Backup of system parameters

Use the function [Backup parameters](#) in [Input / Output](#) to make a backup of the settings and system parameters you have selected for EPCwin.

Data

e.g. D:\

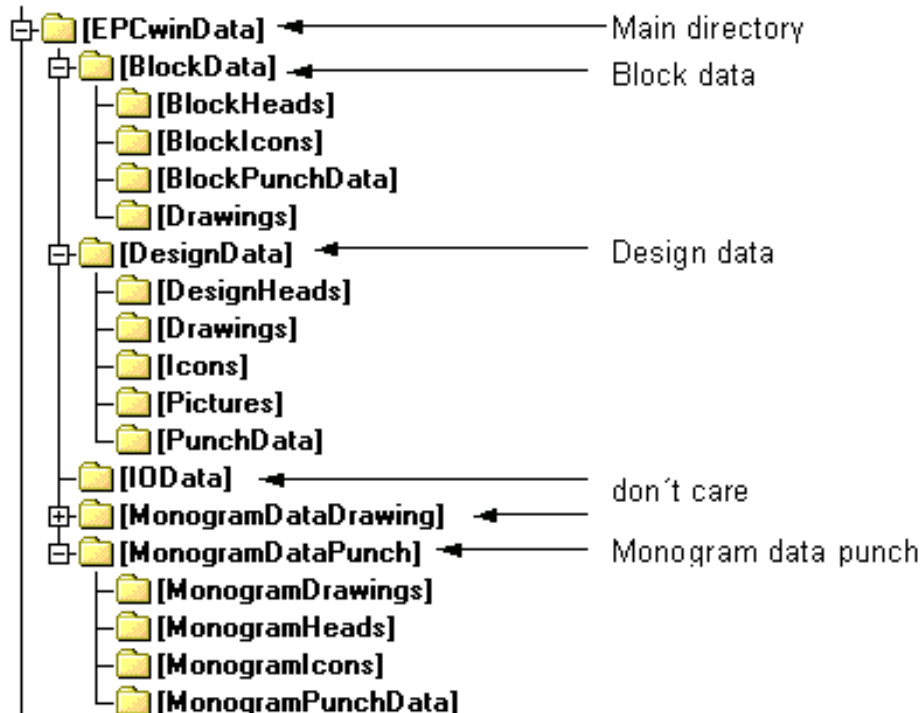

Use a proprietary backup tool to make a backup of your design, block and monogram data. Such tools

allow you to save and reload data according to individual criteria. As a general rule they can also be configured to execute a backup routine automatically, typically every day.

Saving design data (backup)

The design data are generally stored in the directory named *EPCwinData/DesignData*, but you may have created your own design data directories. To make a backup of the design data, you must save the entire content of the relevant directory.

Saving block data (backup)

The block data are generally stored in the directory named *EPCwinData/BlockData*, but you may have created your own block data directories. To make a backup of the block data, you must save the entire content of the relevant directory.

Saving monogram data (backup)

The monogram data are generally stored in the directories named *EPCwinData/MonogrammDataPunch* and *EPCwinData/GiSFonts*, but you may have created your own monogram data directories. To make a backup of the monogram data, you must save the entire content of the relevant directory.

EPCwin system limits and variables

Data structure

Maximum size of reference data/stitch data/program parameters	= 600000
Maximum number of programs	= 4000
Maximum number of special functions	= 6000
Maximum number of markers	= 2000
Maximum number of drawing lines	= 40000
Maximum number of drawing points	= 300000
Maximum number of automatic drawing programs	= 20000
Maximum number of designs open at once	= 9
Maximum number of reference points in a spline	= 1000
Maximum number of contours for selection	= 10000
Pictogram size	= 200x200 pixels

Punching

Max. number of program parameter sets per design	= 60
Max. number of program parameter sets in the system	= 20
Max. number of stitch sequences	= 200
Max. number of stencils	= 200
Max. number of points in stitch sequences	= 400
Max. number of head selections	= 200
Max. number of embroidery heads	= 64
Max. number of different needles per design	= 32

Data memory

Maximum number of entries in general directory	= 10000
Maximum number of markings in general directory	= 2000
Maximum number of markings in block directory	= 2000
Maximum number of block directories	= 99
Maximum number of blocks per block directory	= 99

Maximum number of favorites in general directory = 50

Point/Corner/Straight Line

Maximum number of entries in "SnapList" = 255

Maximum number of selected sub-blocks = 1000

Maximum number of selected points = 10000

Main menu

Starting from the main menu, which is the highest program level, you can call any part of the program by clicking the relevant symbol with <Left>.

The main menu is the starting point in the program for working with designs.

The word "design" is used to describe the entire body of data that contribute to the creation of an embroidered design:

Image: a scanned working copy ([Scanner](#))

Drawing: a technical drawing for embroidery purposes ([Drawing](#))

Stitch data: created with EPCwin or read in from a disk ([Punching](#) and [Disk](#))

Reference data: created with EPCwin ([Punching](#))

Pictogram: created with EPCwin ([Pictogram view](#))

Design head: created with EPCwin. The design head or the design number it contains constitutes the link between all the data that belong to a specific design ([Design head](#))

The main menu has two conditions:

[Main menu without design open](#)

[Main menu with design open](#)

Common to both conditions:



[Scanner](#)



[Imaging](#)



[Input / Output](#)



[True Type Font Editor](#)



[Utilities](#)



[Multi-functionality:](#)

If no design is open, click <Left> on this symbol to close the program.

If a design is open, <Left> closes it.

Main menu without design open

This condition of the main menu offers the following functionality for working with designs:

- Change between multi-head and schiffli
- Create new design
- Open design containing one image
- Open design with existing design data
- Recreate design

Change between multi-head and schiffli



Here you can switch to and from multi-head and schiffli. Clicking <Left> on one of the symbols takes you to **Default settings**, where you can edit further settings applicable to multi-head or schiffli, as appropriate.

Create new design



To create a new design, click on this symbol in the main menu with <Left>. You can then call **Drawing** or **Punching** to enter data.

Open design containing one image



To open a design containing a single image, click on this symbol in the main menu with <Left>.

The **General directory** appears. It shows only the designs that contain only an image, that is to say no drawing data and no stitch data.

In the on-screen dialog select the desired design and confirm your selection with **OK**.

Open design with existing design data



To open a design with existing design data, click on this symbol in the main menu with <Left>.

The **General directory** appears. In the on-screen dialog select the desired design and confirm your selection with **OK**.

Recreate design



While you are working on a design, the EPCwin system automatically creates backup copies. In case of a power failure or if the program is not closed properly, clicking <Left> on this symbol reloads the most recent automatic backup copy. This function covers all the designs that are open when the automatic backup routine is triggered.

You can adjust the interval between automatic backups under **Default settings**.

Additional functions:

Scanner



Imaging



Input / Output



True Type Font Editor



Utilities

Main menu with design open

This condition of the main menu offers the following functionality for working with designs:

- Create another new design
- Open another design containing one image
- Open another design with existing design data
- Save design
- Select active design
- Change dimension system
- Check design
- Design statistics
- Edit design head

- Go to punching
- Go to editor
- Go to drawing
- System parameters
- Global edit
- Grid
- Help tools

Create another new design

For information see [Main menu without design open](#).

Open another design containing one image



For information see [Main menu without design open](#).

Open another design with existing design data



For information see [Main menu without design open](#).

Save design



Clicking <Left> on this symbol opens the on-screen dialog for the [Design head](#). Here you can make further entries in the design head. Confirming with [OK](#) saves the design.

Select active design



Clicking <Left> on this symbol opens the on-screen dialog for [Select active design](#), which enables you to select the current design from a list of the designs that are open.

Change dimension system



Clicking <Left> on this symbol enables you to change the dimension system.

The assistant asks you to enter a dimension system. The system is determined by entering two points and a length. Use <Left> twice in succession to specify two prominent points in the image. The dialog that follows asks you to state the desired distance between the two points. Confirm the dimension with [OK](#).

Check design



Clicking <Left> on this symbol opens the on-screen dialog for [Check design](#). Here you can have the structure of the design examined. If an error is detected, the correction assistant provides guidance on a remedy.

Design statistics



Clicking <Left> on this symbol opens the on-screen dialog for [Design statistics](#). The data that make up the design are processed for statistical evaluation purposes.

Edit design head



Clicking <Left> on this symbol opens the on-screen dialog for [Design head](#). The design head contains a summary of all the data required for design management purposes.

Go to punching



Clicking <Left> on this symbol takes you to **Punching**.

Go to editor



Clicking <Left> on this symbol takes you to the **Main editor**.

Go to drawing



Clicking <Left> on this symbol takes you to **Drawing**.

Parameter settings



Clicking <Left> on this symbol opens the on-screen dialog for **Parameter setting**.

Global edit



Clicking <Left> on this symbol opens the on-screen dialog for **Global edit**. It enables you to change a parameter setting for the entire design, e.g. to change the stitch distance for all objects.

Help tools



Clicking <Left> on this symbol gives you the functionality of **Help tools**.

General Functions

Common **General functions** exist in all program parts for an open design.

Common functions for both main menu conditions:



Scanner



Imaging



Print



Input / Output



True Type Font Editor



Utilities

Select active design

When the on-screen dialog opens, it presents a list of files names corresponding to the open design. The top entry is preselected. You can preview the design whose entry is marked.

Press <Left> to select an entry. Press *Close* to close the design or *Activate* to make it the active design.

Check design

This on-screen dialog enables you to have the current design examined for punch data, design data or special functions that have been entered incorrectly.

To execute a check, first select the desired data type: punch data, design data or special functions. Initiate the checking operation with *Check*. If no errors are detected, a green tick appears alongside punch data, design data or special functions. If an error is detected, a red cross appears together with a button labeled *Repair error*. Clicking <Left> on this button takes you to the editor; the defective element is preselected and the associated error message is displayed in the assistant window. In the case of punch data, for example, the faulty stitch is preselected.

Check repeat jump

Multi-head:

This function checks the integrated repeat jumps by referencing the head selection. Incorrect repeat jump entries are corrected.

Schiffli:

This function checks the integrated repeat jumps by referencing the repeat selection. Incorrect repeat jump entries are corrected.

Design statistics

Multi-head

Schiffli

Design

Design statistics multi-head

This on-screen dialog presents some numerical data concerning the design. You can also enter the relevant factors in the text boxes for *UT* (upper thread factor) and *BT* (bobbin thread factor).

Print enables you to print the statistics.

The statistics cover:

- Design name
- Design number

- No. of Needle change
- No. of Stop
- No. of Thread trimming
- No. of Borer on/off
- No. of Sequin 1 on/off
- No. of Sequin 2 on/off
- No. of Cord on/off
- No. of Loop on/off
- No. of Chain / moos / coil
- No. of Bore points
- No. of sequin 1
- No. of sequin 2
- For the needle colors used in the design:
 - Color
 - Marking
- No. of stitches
- Net stitch length
- Stitch length upper thread
- Stitch length bobbin thread
- Total No. of stitches
 - Total net stitch length
- Total stitch length upper thread
- Total stitch length bobbin thread

Design statistics schiffli

Design statistics design

Design head

The EPCwin design head describes attributes of the design. You make entries in the design head by clicking the boxes you wish to edit. Press *OK* to end the input. Pressing *Cancel* exits the design head without the changes being accepted.

Different design heads exist for schiffli and multi-head designs.

[Design head multi-head](#)

[Design head schiffli](#)

Design head multi-head

The EPCwin design head describes attributes of the design. You make entries in the design head by clicking the boxes you wish to edit. Press *OK* to end the input. Pressing *Cancel* exits the design head without the changes being accepted.

The dialog header indicates the amount of work time expended on the design.

Storage path

Storage path

If the design head is called from an action whose purpose is to save the design, you can specify the storage path.

Home



This function elects the home directory defined with **Default settings** as the current directory.

Favorites

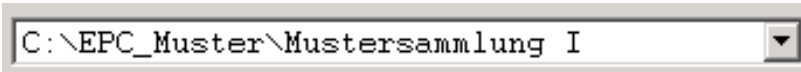

Each data directory you select is documented by the EPCwin system. This enables you to select the desired data directory from the ones you have used in the past.

The EPCwin system manages up to 50 entries. To remove specific entries from the list of favorites, activate the *Delete entry* option and select the data directory you wish to eliminate.

Write protection



A pictogram notifies you if you are not entitled to write in the selected directory.

Identification

To identify a design in the EPCwin directory you make entries in the design head, such as the design name, number etc.. Entries marked (D) also appear in the directory.

Design name (D)

The design name consists of up to 16 alphanumeric characters. This box should contain an entry when you save the design.

Design number (D)

The design and version numbers must be defined at the latest when you save the design. The design number uniquely identifies each design within the directory.

Group (D)

The name of the group consists of up to 16 alphanumeric characters. Enter a category (such as flowers, petals, coats of arms etc.) in this box.

Customer (D)

The name of the customer consists of up to 16 alphanumeric characters.

Customer No.

The customer number consists of up to 10 alphanumeric characters. This is where you can assign a number to the company or client that placed the order.

Commission No.

The job or commission number consists of up to 10 alphanumeric characters. This is where you can

enter the customer's job number.

Puncher

The name of the puncher consists of up to 16 alphanumeric characters.

Artist

The name of the person who created the drawing consists of up to 16 alphanumeric characters.

Start values

Start needle

For the purposes of saving the punch data, the start needle must be entered at the latest when the design is saved. The default setting is needle 1 or the entry in the default design head. Needles 1 to 32 are possible.

Max stitch length [1/10 mm]

The maximum stitch length must be entered at the latest when the design is saved. The default setting is 127 or the entry in the default design head. The entered value must be between 1 and 127. During punching, the maximum stitch length can be changed only to a value lower than the maximum stitch length entered in the design head. If the maximum stitch length in the design head is changed, the stitch lengths in the reference data are also changed accordingly. However, you must calculate the design so that the stitch data are recalculated. The other stitch lengths remain unchanged.

Speed

The machine speed that is to apply at the start of the design is entered here. The dialog that follows gives you the options of *Maximum speed* and an absolute value. You can enter the absolute value only in increments of 10. If you opt for *Maximum speed*, the machine embroiders at its highest possible speed.

Center start

If you have selected *Center start*, the start point will be displaced to the current center of the design when you store the design. The center is calculated from the stitch data.

Repeat

Here you determine whether the design is to be a repeat design. In the *Head spacing* dialog that follows, enter the repeat spacing.

When punching you then have access to special functions 52 for head selection and 53 for head jump.

Head spacing

In the *Head spacing* dialog, set the repeat spacing.

Machine type

Standard

Special functions 42 for boring, 45 for cord, 46 for loop, 50 for 1st sequin, and 51 for 2nd sequin are available if *Standard* is selected.

Cornelly

If you have selected *Cornelly*, special function 47 is available during punching for chain stitch, 48 for moss stitch, and 49 for coiling. When outputting a *Cornelly* design to disk, all the jump stitches are converted to insertion points with one exception: the jump stitches between a needle change or trimming operation and the first insertion point.

Combination machine

If you have selected *Combination machine*, special function 47 is available during punching for embroidery head, 48 for W head, and 49 for K head.

Remarks

You can enter comments on the design comprising up to 114 characters. The first line is always visible in the design head display. The remaining lines are displayed when you click on this field.

Base material

You can enter comments on the base material comprising up to 114 characters. The first line is always visible in the design head display. The remaining lines are displayed when you click on this field.

Fixed values

You cannot edit the values described below. They are calculated from specific variables of the punch and drawing data.

X/Y size (mm)

This field indicates the design size according to the punch data in millimeters: first the width (x), then the height (y).

Number of stitches

This field indicates the number of stitches in the design calculated upon its output as stitch data.

No. of colors

This value indicates how many colors or needles are used in the design.

X/Y drawing (mm)

This field indicates the design size according to the drawing data in millimeters: first the width (x), then the height (y).

No. of points

Indicates the number of drawing line points.

No. of lines

Indicates the number of drawing lines.

Comp. date

Indicates the date and time the design was compiled.

Edit date

Indicates the date and time the design was last modified.

Available data [IDP]

Indicates which data are available for the design.

0 => Not available

1 => Available

I/D/P = Image/drawing/punch data

Design size

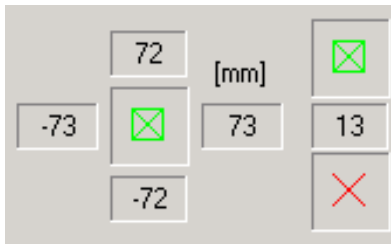

This fields indicate the size of the design in relation to the start point. The green square is the symbol for the start point, and the red diagonals show the end point. The maximum dimensions to the edge of the design are indicated to the left, right, top and bottom of the start point symbol.

The distance between the start and end points is indicated in the middle of the right column where these points are shown.

Special functions

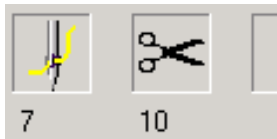

These 16 fields show the special functions that are used in the design and indicate how often they are used.

Needle colors

The color table allows you to set the thread colors for the 32 needles. It shows the needle number, color and designation.

Click [<Left>](#) on the color field to select a color from the color dialog or to mix a new [Color](#). Clicking on the button [Color marking](#) opens an on-screen dialog in which you can enter the color number, color designation and yarn size.

The colors that are used in the design are indicated by a pressed button.

System colors

The color functions described below are available for setting the basic colors used by the system, including to display the reference data and as the background color.

Reference color

Use [Reference color](#) to set the colors for the reference data (contours in the automatic programs).

Background color

[Background color](#) sets the background color of the display.

Dim color

Use [Dim color](#) to select the color for the dimmed stitch data.

(See [View](#))

Repeat color punch

[Repeat color punch](#) selects the color for the depiction of the adjacent repeats for punching.

(See [View](#))

Repeat color design

[Repeat color design](#) selects the color for the depiction of the adjacent repeats for design.

(See [View](#))

Grid main color

Grid main color selects the color for the depiction of the main grid lines.

(See [Grid](#))

Grid secondary color

Grid secondary color selects the color for the depiction of the auxiliary grid lines.

(See [Grid](#))

Sequin 1

Sequin 1 sets the color in which the 1st sequin is depicted.

The size field allows you to set the diameter of sequin 1 in millimeters.

Sequin 2

Sequin 2 sets the color in which the 2nd sequin is depicted.

The size field allows you to set the diameter of sequin 2 in millimeters.

Head spacing

This dialog allows you either to enter a head spacing for a repeat multi-head design directly in the input box or to select the desired spacing from a table.

The table indicates the machine type, number of heads and head spacing. Clicking <Left> on *Machine type*, *No. of heads* or *Head spacing* sorts the table according to the selected criterion.

Clicking <Left><Left> on one of the rows in the table selects the head spacing, accepts the selection, and closes the dialog.

OK

Accepts the selected head spacing (direct number input or selected row in table) and closes the dialog.

Cancel

Rejects the selected head spacing and closes the dialog.

Design head schiffli

The EPCwin design head describes attributes of the design. You make entries in the design head by clicking the boxes you wish to edit. Press *OK* to end the input. Pressing *Cancel* exits the design head without the changes being accepted.

The dialog header indicates the amount of work time expended on the design.

Storage path

Storage path

If the design head is called from an action whose purpose is to save the design, you can specify the storage path.

Home



This function elects the home directory defined with [Data directories / Default setting](#) as the current directory.

Favorites

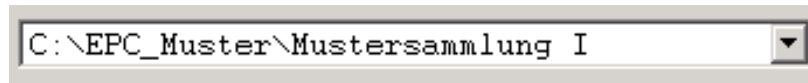

Each data directory you select is documented by the EPCwin system. This enables you to select the desired data directory from the ones you have used in the past.

The EPCwin system manages up to 50 entries. To remove specific entries from the list of favorites, activate the [Delete entry](#) option and select the data directory you wish to eliminate.

Write protection



A pictogram notifies you if you are not entitled to write in the selected directory.

Identification

To identify a design in the EPCwin directory you make entries in the design head, such as the design name, number etc.. Entries marked (D) also appear in the directory.

Design name (D)

The design name consists of up to 16 alphanumeric characters. This box should contain an entry when you save the design.

Design number (D)

The design and version numbers must be defined at the latest when you save the design. The design number uniquely identifies each design within the directory.

Group (D)

The name of the group consists of up to 16 alphanumeric characters. Enter a category (such as flowers, petals, coats of arms etc.) in this box.

Customer (D)

The name of the customer consists of up to 16 alphanumeric characters.

Customer No.

The customer number consists of up to 10 alphanumeric characters. This is where you can assign a number to the company or client that placed the order.

Commission No.

The job or commission number consists of up to 10 alphanumeric characters. This is where you can enter the customer's job number.

Puncher

The name of the puncher consists of up to 16 alphanumeric characters.

Artist

The name of the person who created the drawing consists of up to 16 alphanumeric characters.

Start values

Design type**Single color**

Select this type if the design is to be embroidered in only one color.

Color change stop

Select this type if the design requires the yarn and thus the color to be changed after each stop.

Alternate needle

Select this type if the design consists of several alternating colors. The number of colors is also to be entered in the design head.

R&C (repeat and color change; individual needle selection)

Select this type if the design is to contain repeat changes (fixed repeat and individual needle selections) and repeat jumps.

Max. repeat

Determines the main repeat of a design, e.g. 8/4 (embroidery with alternate heads).

Color repeat

With the R&C design type, "Color repeat" determines the repetition of the colors. The value can differ from that which applies to the main repeat, e.g. in case of individual needle selection. You can check the needle assignment in [Needle-color assignment](#).

Basic repeat

With the R&C design type, "Basic repeat" determines the repeat size of basic elements. This is important when programming single-needle designs.

No. of colors

With the "Alternate needle" design type, this value determines the number of alternating colors.

Max stitch length [1/10 mm]

The maximum stitch length must be entered at the latest when the design is saved. The default setting is 171 or the entry in the default design head. The entered value must be between 1 and 171. During punching, the maximum stitch length can be changed only to a value lower than the maximum stitch length entered in the design head. If the maximum stitch length in the design head is changed, the stitch lengths in the reference data are also changed accordingly. However, you must calculate the design so that the stitch data are recalculated. The other stitch lengths remain unchanged.

Remarks

You can enter comments on the design comprising up to 114 characters. The first line is always visible in the design head display. The remaining lines are displayed when you click on this field.

Base material

You can enter comments on the base material comprising up to 114 characters. The first line is always visible in the design head display. The remaining lines are displayed when you click on this field.

Fixed values

You cannot edit the values described below. They are calculated from specific variables of the punch and drawing data.

X/Y size (mm)

This field indicates the design size according to the punch data in millimeters: first the width (x), then

the height (y).

Number of stitches

This field indicates the number of stitches in the design calculated upon its output as stitch data.

No. of colors

This value indicates how many colors or needles are used in the design.

X/Y drawing (mm)

This field indicates the design size according to the drawing data in millimeters: first the width (x), then the height (y).

No. of points

Indicates the number of drawing line points.

No. of lines

Indicates the number of drawing lines.

Comp. date

Indicates the date and time the design was compiled.

Edit date

Indicates the date and time the design was last modified.

Available data [IDP]

Indicates which data are available for the design.

0 => Not available

1 => Available

I/D/P = Image/drawing/punch data

Design size

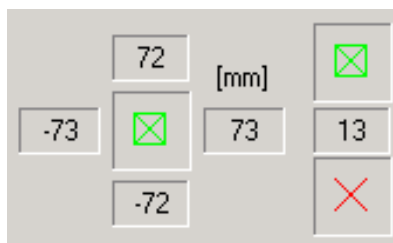

This fields indicate the size of the design in relation to the start point. The green square is the symbol for the start point, and the red diagonals show the end point. The maximum dimensions to the edge of the design are indicated to the left, right, top and bottom of the start point symbol.

The distance between the start and end points is indicated in the middle of the right column where these points are shown.

Special functions

These 16 fields show the special functions that are used in the design and indicate how often they are used.

Needle colors

This color table allows you to define 16 colors. It shows the color, first needle number with this color, and the designation.

Click <Left> on the color field to select a **Color** from the color dialog or to mix a new color. Clicking on the button *Color marking* opens an on-screen dialog in which you can enter the color number, color designation and yarn size.

The colors that are used in the design are indicated by a pressed button.

Needle-color assignment



You can edit and check the **Needle-color assignment** here.

Special function start statuses

Here you set the initial states of the **Special functions** applicable at the start of the design.

System colors

The color functions described below are available for setting the basic colors used by the system, including to display the reference data and as the background color.

Reference color

Use *Reference color* to set the colors for the reference data (contours in the automatic programs).

Background color

Background color sets the background color of the display.

Dim color

Use *Dim color* to select the color for the dimmed stitch data.

(See **View**)

Repeat color punch

Repeat color punch selects the color for the depiction of the adjacent repeats for punching.

(See **View**)

Repeat color design

Repeat color design selects the color for the depiction of the adjacent repeats for design.

(See **View**)

Grid main color

Grid main color selects the color for the depiction of the main grid lines.

(See **Grid**)

Grid secondary color

Grid secondary color selects the color for the depiction of the auxiliary grid lines.

(See **Grid**)

Sequin 1

Sequin 1 sets the color in which the 1st sequin is depicted.

The size field allows you to set the diameter of sequin 1 in millimeters.

Color definition

This on-screen dialog allows you to determine the needle colors and some system colors. 32 colors are available for multi-head designs, and 16 colors for schiffli designs. As regards system colors, both the background color and the dim color can be selected for multi-head and schiffli designs. The color you select applies either for one needle or for one of the system colors.

Needle color

This dialog presents buttons for the individual colors. From among the specified needles, press the button for which the color setting is to apply. A needle color may be preselected when this dialog is called.

System colors

Here you can select either the dim color or the background color for which the color setting is to apply.

Yarn manufacturer

You can select a yarn manufacturer here. The choice you make here determines the colors that appear in the color table and the color numbers that can be entered.

Yarn data

Color number

Here you can enter a color number, as issued by the selected yarn manufacturer.

Color name

Here you can enter a color name (any text) irrespective of the selected manufacturer and color number.

Yarn size

Here you can enter a yarn size irrespective of the selected manufacturer and color number.

Used colors

The color fields representing the colors used in the design are presented here. Click <Left> on a color field to assign the color to the selected needle or system color.

Mix

This button calls the standard Windows dialog for creating a color manually.

Color table

This button calls the **Color table dialog** for selecting a color from the selected yarn manufacturer's color tables.

Delete

Pressing this button deletes the color of the selected needle or system color.

Change

Pressing this button initiates the routine for exchanging two colors. If you select a different color, it is exchanged for the one that is selected. Alternatively, you can close the exchange routine by selecting

End change.

End change

This button appears if you have selected *Change*.

Ok

This button accepts the settings and closes the dialog.

Cancel

This button rejects the settings and closes the dialog.

Color table

This dialog enables you to select the color value according to the color number issued by the yarn manufacturer.

If the color number specified in the *Color definition dialog* is contained in this dialog when it is called, this is the defaulted number.

The relevant RGB color value and, if available, the associated Pantone Matching value are indicated alongside the color number buttons.

Clicking <Left> twice on a color field in the color table, which can be scrolled, accepts the associated color number and color value, and closes the dialog.

Clicking <Left> once on a button selects the associated color number and color value.

OK

Accepts the color number and associated color value, and closes the dialog.

Cancel

Rejects the color number and color value, and closes the dialog.

Maker info

Pressing this button calls another dialog containing further information about the manufacturer (postal and internet addresses).

Manufacturer

Shows the name of the manufacturer.

Product line

Here you can select the yarn manufacturer's product line according to the release. The relevant color table is then displayed.

Release

Here you can select the release according to the yarn manufacturer's product line. The relevant color table is then displayed.

Yarn size

Here you can select the yarn size according to the yarn manufacturer's product line and release.

Material

The yarn's material designation is displayed here according to the product line.

Needle-color assignment

This dialog enables you to program the needle assignment for a schiffli design.

The key elements of this dialog are the color field buttons assigned to the needle numbers, the color reset button, the horizontal and vertical scroll bars, and the *OK* and *Cancel* buttons

Color field buttons

Clicking <Left> on one of these buttons opens another dialog that enables you to determine the color for the selected needle.

Scroll bars

Use the horizontal and vertical scroll bars as you do when working with windows. When you scroll in this dialog, the area showing the needle numbers, the allocated color assignments and the needle designs is displaced accordingly.

Color reset upon maximum repeat

If this button is set, the system starts afresh with the color assignment after each maximum repeat.

If it is not set, the color assignment is repeated after each color repeat.

OK

Pressing this button accepts the allocation of the color assignment for the needles and closes the dialog.

Cancel

This button closes the dialog. The allocation of the color assignment for the needles is rejected.

General Functions

- Display
- View
- Help tools
- Measuring

Display

- Scrolling
- Zoom
- Center design

Scrolling

There are three ways of displacing the design or part of the design, as described below:

Cursor keys

These shift the design or design section in the appropriate direction. The screen display cannot be scrolled with the cursor keys in the editor because they execute a different function there.

Mouse

When you reach the edge of the working window with the mouse, the design is displaced in the appropriate direction. If you move the mouse to the top of the window, for example, the design or design section is scrolled downwards.

Overview window

When you press the [Space bar] and move the mouse, the rectangle in the overview window tracks the movement of the mouse. Press <Left> to confirm that the current section is the one you wish to view; it is depicted in the working window.

Zoom

Three options are available for zooming:

Manual input of a zoom factor

Press [-] on the number keypad and then enter a digit from 1 to 9 to enter the zoom factor directly. To reduce the size of the display by entering a zoom factor of less than 1, press [-] a second time before entering the digit. The applied formula is $1 / x$. Example: for a zoom factor of 0.5, enter [-] [-] [2]

Tracing a rectangle

Press [-] on the number keypad and enter two points to determine the new image section; the new zoom factor is calculated automatically.

With [Page up] and [Page down]

[Page up] and [Page down] change the zoom factor by the zoom offset value. The zoom offset value is edited in the [Default settingsID_Grundeinstellung Allgemein](#).

Center design

Use [C] to center the design. A new zoom factor is calculated to depict the entire design in the working window. Pressing [C] again switches back to the previous zoom factor.

Exceptions in the editor:

You have preselected a stitch within an object: The object is centered and a new zoom factor is calculated to depict the entire object in the working window.

You have preselected a manual stitch: The area between the two objects is centered and a new zoom factor is calculated to depict the entire area in the working window.

A bounding box is active. The box is centered and a new zoom factor is calculated to depict the entire box in the working window.

View

[F2] takes you to the View tool (on-screen dialog).

This tool gives you various options for adjusting the display of your data.

By selecting and deselecting the appropriate options, you can improve the clarity of the design

depiction for processing purposes.

As a general rule, a button that is depicted as pressed indicates that the corresponding View option is selected.

The View tool comprises four areas:

- Settings for viewing image data
- Settings for viewing drawing data
- Settings for viewing punch data (reference and stitch data)
- Settings for viewing the additional tools (graphic aids)

The Shortcut button allows you to execute an action directly by entering a digit.

Press *OK* to accept the chosen settings or *Cancel* to close the dialog without accepting the settings.

Settings for viewing image data (*Image frame*):

On/Off

Selects and deselects depiction of the image.

Display

Pressing this button displays the brightness and contrast settings.

Slide control for brightness and contrast:

For increasing (+ direction) or decreasing (- direction) the brightness and saturation values.

Settings for viewing drawing data (*Drawing frame*):

On/Off

Selects and deselects depiction of all the drawing data.

Buttons for colors numbered 1 - 8 and 1 - 16:

The first 8 colors are predefined, colors 1 - 16 correspond to the needle colors 1 - 16 in the design. Only the buttons shown underneath a color are significant. These are the colors used in the design.

Repeat

This function selects and deselects the repeat view of the drawing lines.

Settings for viewing punch data (*Punching data frame*):

On/Off

Selects and deselects depiction of all the punch data.

Settings by way of needle color

Stitch data

Selects and deselects depiction of all the stitch data.

This button is relevant only if the punch data option is selected.

Buttons for stitch data numbered 1 - 32:

For selecting and deselecting the depiction of stitches in the relevant color.

Only the buttons shown underneath a color are significant. These are the colors used in the design.

Reference data

Selects and deselects depiction of all the reference data.

This button is relevant only if the punch data option is selected.

Buttons for reference data numbered 1 - 32:

For selecting and deselecting the depiction of reference data in the relevant color.

Only the buttons shown underneath a color are significant. These are the colors used in the design.

Settings by way of automatic program:**Stitch data prog.**

Selects and deselects depiction of all the stitch data generated by automatic programs.

Buttons for stitch data prog.

For selecting and deselecting the depiction of stitch data in individual automatic programs.

Reference data prog.

Selects and deselects depiction of all the reference data.

Buttons for reference data prog.

For selecting and deselecting the depiction of reference data in individual automatic programs.

Underlay prog.

Selects and deselects depiction of all programs containing underlays.

Buttons for underlay prog.

For selecting and deselecting the depiction of individual automatic programs for underlays.

Block list

This function enables you to select and deselect the [Block list](#).

Repeat view:

If repeat view is selected for the design, an icon button indicating the current setting appears as well. It is used to call the on-screen dialog [Repeat view](#).

Settings for viewing additional tools ([Additional tools frame](#))**True image I, True image II**

Switches the display to True image I or II, to give a realistic impression of the design's stitch data. The stitches are distinguished by line thickness. This setting reduces the drawing speed and deselects depiction of the reference and drawing data.

Stitch point prog.

Selects and deselects depiction of the program stitch points.

Manual stitch points

Selects and deselects depiction of the manual stitch points.

Overview

Selects and deselects the overview window. The overview window is redrawn when refresh or zoom is selected.

Scrolling

Selects and deselects automatic image displacement when you reach the edge of the working window.

Bore points

Switches the color of the boring points between the reference data color and the predetermined color (red). The reference data color is defined in the [Design head](#).

Color of ref. data

Switches the color of the reference data of an object between the reference data color and the needle color. The reference data color is defined in the [Design head](#).

G: Grid

Selects and deselects depiction of the grid.

H: Help lines

Selects and deselects depiction of the help lines.

T: Remarks

Selects and deselects depiction of the remarks.

Common button for G H T

Selects and deselects depiction of the grid, help lines and remarks.

Drawing points

Selects and deselects depiction of the reference points in the drawing lines.

Reset

Accepts the view settings made under [Default settings](#).

Preview

Press this button to check the current setting of the on-screen dialog in the working or overview window.

Repeat view

For multi-head embroidery with head selection or schiffli, various options are available for repeat view. With multi-head designs, these options are available if *Machine type* : *Repeat* is specified in the [Design head](#).

Main repeat

All the stitch and reference data switched on in 'View' are shown in the main repeat (punch input). The repeat joins are not visible.

Neighbour repeat:

All the stitch and reference data switched on in 'View' are shown in the main repeat (punch input) and one repeat is shown to the left and to the right. The repeat joins are visible.

The following options are available for the adjacent repeat:



Stitches in repeat color



Stitches in color



Reference data in repeat color



Reference data in color

Full repeat

All the stitch and reference data switched on in 'View' are shown in the main repeat (punch input) and all the repeats to the left and right are shown. The repeat joins are visible.

The following options are available for the adjacent repeats:



Stitches in repeat color



Stitches in color



Reference data in repeat color



Reference data in color

For further information see [Head selection](#)

Help tools

The functions available under "Help tools" enable you to define help lines, remarks and grids. The help lines can be positioned horizontally, vertically or at an angle. You can determine the color and length of the help lines. When entering remarks, you can stipulate the font, character height, font color and line spacing.

Start help tools



Clicking <Left> on this symbol starts the help tools. Alternatively, when working with the editor, drawing or punching, press key [H].

Grid



Pressing [F6] enables you to define a [Grid](#).

Remarks



Pressing [F7] gives you the functionality of [Remarks](#).

Horizontal help line



Pressing [F8] selects the horizontal help line function. Clicking <Left> generates a horizontal help line with the defined length and color. The position at which you click marks the center point of the help line unless you have previously selected the design size with the [Help line parameters](#). In this case, the position at which you click is not the center point; the horizontal help line extends from the left to the right horizontal extreme of the design.

Vertical help line



Pressing [F9] selects the vertical help line function. Clicking <Left> generates a vertical help line with the defined length and color. The position at which you click marks the center point of the help line unless you have previously selected the design size with the [Help line parameters](#). In this case, the position at which you click is not the center point; the vertical help line extends from the top to the bottom vertical extreme of the design.

Angled help line



Pressing [F10] selects the angled help line function. Clicking <Left> generates a help line with the defined angle, length and color. The position at which you click marks the center point of the help line.

Help line parameter



Pressing [F11] calls the dialog for setting the [Help line parameters](#).

Select color



Pressing [F12] calls the dialog for selecting the font color.

Help line parameter

The dialog for setting the help line parameters enables you to define the help line length, angle and color.

Help line length



Here you can enter the length of the help line in mm in the range 1 to 300 mm.

Design size

Design size sets the value for the horizontal help lines to match that of the current horizontal design span, and the value for the vertical help lines to match that of the current vertical reach of the design. This button closes the dialog.

Angle



If you have selected an angled help line, here you can determine the angle of the help line in the range – 90 to 90 degrees.

Color



Pressing *Color* calls the dialog for selecting the color of the remarks.

Grid



To initiate the grid function either press <Left> on this symbol in the main menu or press [F6] when working with the *Help tools* or creating a new design with schiffli.

A grid dialog appears on the screen. Once the dialog is closed, in case of a new entry or if you press *Move grid* in the grid dialog, the grid moving routine is started. You can position the grid according to your needs. Click <Left> to confirm the position. Pressing *Esc* aborts positioning.

Grid dialog

Expansion

Proportional



If the value for width or height is entered manually, press this button to have the other value calculated in proportion to the manual input.

Repeat grid

When this button is enabled, the height and width are set to preset repeat values.

It is activated with schiffli designs and with multi-head designs that are set to repeat in the design head.

Width, Height

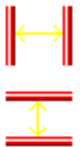

When the dialog opens, the current dimensions of the grid cell are shown here; they can be entered manually.

Line type

Dashed grid main line

If this button is enabled, the main lines of the grid are drawn as dashed lines.

Dashed grid auxiliary line

If this button is enabled, the auxiliary lines of the grid, if set with the repeat options, are drawn as dashed lines.

It is activated with schiffli designs and with multi-head designs that are set to repeat in the design

head.

Grid options

Snap radius



See [Contour](#)

In the associated text field you can enter the snap radius for the input of design and punch data (reference points). The radius applies to both the x and the y direction.

Display grid

The button selects and deselects depiction of the grid lines.

Repeat options

Repeat number display

If this button is enabled, repeat numbers are displayed as well.

It is activated with schiffli designs and with multi-head designs that are set to repeat in the design head.

Grid auxiliary lines

If this button is enabled, grid auxiliary lines are drawn. The associated text field specifies the number of auxiliary lines that are to be drawn between two grid main lines.

Delete grid

Deletes the grid and closes the dialog.

Remarks

The Remarks function enables you to enter several lines of remarks. You can determine the font, character height, font color and line spacing.

Start point of remarks

You have to enter a start point before you can write the remarks at the desired place in the design. Clicking `<Left>` fixes the position. The start point refers to the bottom left corner of the first line, where a cursor appears ("_").

Remarks parameters



Pressing `[F11]` calls the dialog for setting the [Remarks parameters](#).

Select color



Pressing `[F12]` calls the dialog for selecting the font color.

Entering remarks

Once you have defined the start point, you can enter the remarks at the keyboard.

Pressing <Left> determines a new start point for entering remarks.

Pressing [Backspace] deletes the letter to the left of the cursor.

Pressing [Shift] + [Return] starts a new line.

Pressing [Return] accepts the entered remarks and terminates the text input.

Pressing [Esc] aborts the remarks input routine. The remarks entered since defining the last start point are deleted.

Remarks parameters



Pressing [F11] calls the dialog for setting the **Remarks parameters**.

Select color



Pressing [F12] calls the dialog for selecting the font color.

Remarks parameters

The dialog for setting the remarks parameters enables you to define the character height in mm, line spacing in mm, the font and the color of the remarks.

Character height



Here you can enter the character height in mm in the range 1 to 1000 mm.

Line space



Here you can enter the line spacing in mm in the range 1 to 100 mm.

Font



Calls the dialog for determining the font.

Color



Pressing *Color* calls the dialog for selecting the color of the remarks.

Measuring



Start measuring by pressing <Left> on this symbol In the main menu or, in the editor or when drawing or punching, by pressing [M] .

Then determine two measuring points, one after the other, in one of three ways:

- Clicking <Left> enters the measuring point in the design at the cursor position.
- [Shift] + <Left> is the option for entering the measuring point by approaching an element (e.g. contour, grid).
- <Left><Left> has the same effect as <Left>, except that a marker is placed at the measuring point as well.

Once the first measuring point is determined, the assistant displays the current values each time the mouse is moved. After the second measuring point is entered, the display is "frozen".

You can now initiate another measurement. Press [Esc] to exit the measuring function. Pressing [Esc] after entering the first point deletes the point.

Pressing [Div] places a marker in the position currently occupied by the mouse. Pressing [Backspace] deletes the most recently entered marker. Each time you press [Backspace], the preceding marker is deleted. This applies to all markers created during a measuring operation.

Parameter settings

Punch



Parameter sets



Ramps



Stencil



Stitch sequence

Drawing



Parameter sets

Multi-Head



Head selection

Schiffli



Program SF Display



Needle pattern

Text

Text

Parameter set

A parameter set (PS) comprises all the parameters in an automatic program. A distinction is made between design parameter sets (DPS) and system parameter sets (SPS). The design parameter sets are linked to a design. The system parameter sets are available in all designs. You can create and store 20 system parameter sets per automatic program and 60 design parameter sets per design.

The top part of the PS mask contains a list of the individual parameter sets. An occupied PS is denoted by an * above the number. Select a PS with <Left>. The bottom part of the mask shows the parameters.

If you select a system parameter set during punching, it is copied to the design parameter set.

Editing a system parameter set

In the main menu click *Parameter settings* and then *Parameter sets*. Select the program type. Click the number of the parameter set you wish to edit or use as the basis of a new parameter set.

Select the parameter you wish to edit with <Left>. In the case of parameters with numerical values, enter the new value. The value range is shown at the bottom left. A warning is issued in the relevant box if you make an entry that is outside the valid range. If you move to another parameter without correcting the mistake, the former value is retained. If the parameter does not have a numerical value, a list appears; click the desired setting.

In the case of the stencil (program 10), stitch distance ramp (program 1 - 6) and stitch sequence (program 6) parameters, a list appears above the parameter mask. Click the desired pictogram. If the list is larger than can be depicted with the available pictogram windows, navigate through the list by clicking << and >>.

Once you have set all the parameters, click *Save* and then click on the parameter set number under which you wish to save the new settings. If the number has already been assigned (*), you have to confirm that you wish to overwrite the existing parameter set.

If you wish to delete a system parameter set, select it as described above and then click *Delete*.

To create a new parameter set, either take an existing one as a template and edit the individual parameters as required, or click on *New*. In this case, all the parameters are defaulted.

Information

Overwriting a system parameter set has no direct repercussions for a design.

Parameter Program Satin stitch

General information concerning parameter sets is contained under [Parameter set](#).

General parameters

Stitch distance ramp



0 = No ramp

1 - 10 Ramp number

The stitch distance ramp sets the stitch distance according to the width of the object. [Stitch distance ramps](#)

Start stitch shortening

0 - 100 %

0 - 100%

If the outside edge is much longer than the inside edge (strongly arched curve, tight corner), the stitches are shortened if a value greater than 0 is entered for stitch shortening. The initial setting for stitch shortening is set in the parameter set. If the value is to change within the object, enter the change under stitch direction.

Move

-20 to 20 1/10 mm

The shortened stitches are displaced in the running direction of the filling. This parameter enables the stitch insertion point to be concealed by the following stitch.

Min. stitch length

1 - 127 1/10 mm

No stitch is generated whose axial length is shorter than the minimum stitch length. We recommend the selection of a value no less than 5/10 mm and no greater than 15/10 mm.

Pull compensation

-99 - 999 %

The pull compensation indicates the value which can be used to manipulate the satin stitch contour in order to equalize the thread tension. The pull compensation values must be entered twice, as both a percentage (%) and an absolute value (LIMIT). The percentage indicates by what amount in per cent the contour is widened in relation to the satin stitch length. The percentage widening of the entire satin stitch, however, must not exceed the absolute value (LIMIT) on each side.

Limit

0 - 100 1/10 mm

See pull compensation

Underlay: Running**No. of runnings**

1..n

0 - 3

0 = Only one running stitch line underlay is generated if required for processing purposes.

1 = The running stitch line is generated at least once on each side of the contour.

2 = The running stitch line is generated at least twice on each side of the contour.

3 = The running stitch line is generated at least three times on each side of the contour.

Running space



0 - 999 1/10 mm

This parameter sets the size of the space between the running stitch line and the edge of the object. It is required only with Run. side 1 or 3. If the space causes the running stitch line to overstep the center of the object, the line is shifted to trace a line along the center of the object at these narrow points.

Running stitch length



1 - 99 1/10 mm

This parameter determines the length of the running stitches.

Running - side

0 = The running stitch line traces a line along the center of the object; no zigzag underlays are generated with this setting.



1 = The space for the running stitch line is measured on side 1 of the object (green arrows indicates the side).



2 = The space for the running stitch line is measured on side 2 of the object.



3 = The space for the running stitch line is measured on both sides of the object.



Running swing



0 - 99 1/10 mm

This parameter sets the clearance between the insertion points and the normal running stitch line (lateral deflection or swing). The swing is applied only to the last path.

Running shift

This parameter determines the amount of offset (shift) between the insertion points in relation to the normal running stitch line.

1 = No shift



2 = 1st running stitch line no shift
 2nd running stitch line shifted by 1/2



Underlay: Zigzag

Overlapping stitches



0 - 9

This entry indicates how many stitches should overlap at the interface of the satin stitch program. Interfaces are created when the object has to be filled in two parts owing to the position of the start and end points. The number of overlap stitches is incremented by 1 if the set running side cannot be executed with the set number of stitches.

ZigZag



0 - 2

0 = No zigzag underlays
 1 = One zigzag underlay (outward direction)
 2 = Two zigzag underlays (outward and inward)

ZZ. Space



0 - 999 1/10 mm

This parameter sets the size of the space between the zigzag underlay and the edge of the object.

ZZ. Distance



This parameter determines the distance between the consecutive stitches that form the zigzag. It is usually fairly large.

ZZ. Offset



1 - 5

This parameter determines the slant of the zigzag underlay. 1 is a slight slant and 5 is a steep slant.

ZZ. Max length



0 - 127 1/10 mm

Set this parameter to 0 if you do not wish to restrict the length of the stitches that make up the zigzag underlay. Otherwise, enter a maximum stitch length; stitches that are too long are then divided into

several insertion points.

Reverse type and jagged parameters

Reverse type

A single reversing point is generated at the design contour from the immediately adjacent points located on the design contour in line with optimum embroidering criteria.



The program approaches the two adjacent points on the design contour and links them with a stitch. Since these two points are generally located very close together, the stitch length may fall below the set minimum at this point.



The third type of turn is a mixture of the previous two. A single point is generated from the last subdivision.



Jagged



On/off

Range

0 - 99 1/10 mm or 0 - 100 %

The satin stitch can be jagged on side 1 (S1) and/or side 2 (S2). Enter the maximum jag range in 1/10 mm or as a percentage. If values greater than 0 are entered for all parameters, the percentage value is taken.

Parameter Program Irregular divided satin stitch

General information concerning parameter sets is contained under [Parameter set](#).

For a description of the common parameters within the satin stitch family, see [Parameter Program satin stitch](#).

Stitch type parameters

Move



-99 to 99 1/10 mm

The first dividing stitch is shifted in the running direction of the filling. This parameter is designed in particular to prevent the thread being damaged by the needle if the short-long rule is violated.

Max step length



1 - 127 1/10 mm

Enter the maximum stitch length for casual stitch division here.

Min step length



1 - 127 1/10 mm

Enter the minimum stitch length for casual stitch division here.

Parameter Program Percentual Satin stitch

General information concerning parameter sets is contained under [Parameter set](#).

For a description of the common parameters within the satin stitch family, see [Parameter Program satin stitch](#).

Stitch type parameters

Move



-99 to 99 1/10 mm

The first dividing stitch is shifted in the running direction of the filling. This parameter is designed in particular to prevent the thread being damaged by the needle if the short-long rule is violated.

1st dividing ratio



1 - 100 %

Enter the value for the first division as a percentage. Together, the three division ratios must not exceed 100.

2nd dividing ratio



1 - 100 %

Enter the value for the second division as a percentage.

3rd dividing ratio



1 - 100 %

Enter the value for the third division as a percentage.

Parameter Program Systematical divided Satin stitch

General information concerning parameter sets is contained under [Parameter set](#).

For a description of the common parameters within the satin stitch family, see [Parameter Program satin stitch](#).

Stitch type parameters

Move



-99 to 99 1/10 mm

The first dividing stitch is shifted in the running direction of the filling. This parameter is designed in particular to prevent the thread being damaged by the needle if the short-long rule is violated.

Braiding type



- 1 = stitch insertion with every dividing line
- 2 = stitch insertion every 2nd dividing line
- 3 = stitch insertion with every 3rd dividing line
- 4 = stitch insertion with every 4th dividing line

Move division line



0 - 127 1/10 mm

The stitch insertion points on a dividing line are displaced by half the value in the running direction. An input of 0 places the insertion point on the dividing line.

Parameter Program Variable Satin stitch

General information concerning parameter sets is contained under [Parameter set](#).

For a description of the common parameters within the satin stitch family, see [Parameter Program satin stitch](#).

Stitch types

The stitch type indicates how the stitch belonging to the stitch block is to be divided. A maximum of five stitch blocks can be formed.

- 0 = No additional stitch blocks
- 1 = Undivided
- 2 = Casually divided
- 3 = Divided by percentage
- 4 = Systematically divided
- 5 = Fixed number of divisions
- 6 = Fixed stitch length

7 = Fixed stitch length with shift

8 = Divided with fixed spacing

Press the button *Display parameters* to obtain a display of the parameters for this stitch block.

Stitch type parameters

Stitches per block



1 - 999

This number indicates the frequency with which the individual stitch element is to be repeated and how many stitches belong to this block.

Move Stitch type 2-8



-99 to 99 1/10 mm

The first dividing stitch is shifted in the running direction of the filling. This parameter is designed in particular to prevent the thread being damaged by the needle if the short-long rule is violated.

Max step length Stitch type 2



1 - 127 1/10 mm

Enter the maximum stitch length for casual stitch division here.

Min step length Stitch type 2



1 - 127 1/10 mm

Enter the minimum stitch length for casual stitch division here.

1st dividing ratio Stitch type 3



1 - 100 %

Enter the value for the first division as a percentage. Together, the three division ratios must not exceed 100.

2nd dividing ratio Stitch type 3



1 - 100 %

Enter the value for the second division as a percentage.

3rd dividing ratio Stitch type 3



1 - 100 %

Enter the value for the third division as a percentage.

Braiding type Stitch type 4



1 = stitch insertion with every dividing line

2 = stitch insertion every 2nd dividing line

3 = stitch insertion with every 3rd dividing line

4 = stitch insertion with every 4th dividing line

Move division line Stitch type 4



0 - 127 1/10 mm

The stitch insertion points on a dividing line are displaced by half the value in the running direction. An input of 0 places the insertion point on the dividing line.

Number of division Stitch type 5



1 - 99

The satin stitch is divided uniformly as often as necessary to produce the number of dividing lines. The stitch is divided into the specified 'No.' of parts.

Step length Stitch type 6, 7



1 - 999 1/10 mm

The associated satin stitch is divided according to the specified stitch length. The beginning of the division is always on the side of the contour on which the start point of the automatic program is also located.

Shift Stitch type 7



0 - 100%

The parameter states the percentage shift of the stitches in relation to the previous stitch block.

Repeat Stitch type 7



0 or number

0 = no repetition of type

Number = the start point of the division from the preceding stitch to the subsequent stitch is inherited. The inherited information is retained over the number of stitches specified under *stitches per block*. Thereafter the division is shifted according to a percentage

Fixed spacing Stitch type 8

0 - 99 1/10 mm

A stitch furrow whose width corresponds to the set value and is defined by two stitch contours is generated in the center of the design.

Parameter Program Definable Stitch-sequences

General information concerning parameter sets is contained under [Parameter set](#).

For a description of the common parameters within the satin stitch family, see [Parameter Program satin stitch](#).

Stitch type parameters**Stitch sequence**

0 = no sequences (zigzag)

1 - 200 = free sequences

[Stitch sequences](#)

Max. stitch length

Division of long stitches

0 = No division

Parameter Program Complex Stepstitch Fill

General information concerning parameter sets is contained under [Parameter set](#).

General parameters**Min. stitch length**

1 - 127 1/10 mm

No stitch is generated whose axial length is shorter than the minimum stitch length. We recommend the selection of a value no less than 5/10 mm and no greater than 15/10 mm.

Pull compensation

-99 - 999 %

The pull compensation indicates the value which can be used to manipulate the satin stitch contour in order to equalize the thread tension. The pull compensation values must be entered twice, as both a percentage (%) and an absolute value (LIMIT). The percentage indicates by what amount in per cent the contour is widened in relation to the satin stitch length. The percentage widening of the entire satin stitch, however, must not exceed the absolute value (LIMIT) on each side.

Limit



0 - 100 1/10 mm

See pull compensation

Reverse type

The program approaches the two adjacent points on the design contour and links them with a stitch. Since these two points are generally located very close together, the stitch length may fall below the set minimum at this point.



The third type of turn is a mixture of the previous two. A single point is generated from the last subdivision.



Move division line



0 - 127 1/10 mm

The stitch insertion points on a dividing line are displaced by half the value in the running direction. An input of 0 places the insertion point on the dividing line.

Overlap



0, 2, 4, 6, 8

One overlap fewer is generated in areas where the filling lies in opposite directions.

Underlay: Running

No. of runnings

1..n

1 - 3

The running stitch line is generated parallel to the outline according to the number input.

Running space



0 - 999 1/10 mm

This parameter sets the size of the space between the running stitch line and the edge of the object; the value should not normally be less than 10 1/10 mm. With pull compensation selected, the space for the running stitch line always refers to the recalculated design contour.

Running stitch length



This parameter determines the length of the running stitches. Do not enter large values, but only ones between 20 and 35 1/10 mm.

Running swing



0 - 99 1/10 mm

This parameter sets the clearance between the insertion points and the normal running stitch line (lateral deflection or swing). The swing is applied only to the last path

Running shift

This parameter determines the amount of offset (shift) between the insertion points in relation to the normal running stitch line.

1 = No shift



2 = 1st running stitch line no shift

2nd running stitch line shifted by 1/2



Underlay: ZigZag

No. of ZigZags



0 - 2

0 = No zigzag underlays

1 = One zigzag underlay (outward direction)

2 = Two zigzag underlays (outward and inward)

ZZ. Space



0 - 999 1/10 mm

This parameter sets the size of the space between the zigzag underlay and the edge of the object.

ZZ. Distance



This parameter determines the distance between the consecutive stitches that form the zigzag. It is usually fairly large.

Angle



0 - 45°

This parameter determines the angle between the stitch direction marker of the zigzag underlay and that of the object.

ZZ. Rhythm



1 - 8

See Rhythm

ZZ. Stitch length



1 - 127

This parameter determines the length of the stitches for the zigzag underlay (rhythm).

Rhythm

Rhythm



0 - 8, 9, 10

0 = No stitch marks

1 = No rhythm

2 = 1/2 rhythm

3 = 1/3 rhythm

4 = 1/4 rhythm

5 = 1/5 rhythm

6 = 1/6 rhythm

7 = 1/7 rhythm

8 = 1/8 rhythm

9 = Casually divided rhythm

The stitch marks vary between a minimum and maximum stitch length so that no stitch contours are created.

10 = Offset angle

The stitch contours form the set angle.

Step length rhythm 1 - 8 and 10



1 - 127 1/10 mm

Enter the step lengths of the running stitch lines here.

Max step length rhythm 9



1 - 127 1/10 mm

Enter the maximum stitch length for casual stitch division here.

Min. step length rhythm 9



1 - 127 1/10 mm

Enter the minimum stitch length for casual stitch division here.

Dividing angle rhythm 10



10 - 80°; 100 - 170°

Enter the angle of the stitch lines here.

Stencil

Stencil



1 - 200

Enter the number of the stencil you wish to use. **Stencil**

Stencil width



1 - 999 1/10 mm

Enter the width of the stencil here. The stencil height is automatically calculated from the proportions of the original stencil. This affects the length of the stitches. The longest stitch corresponds to the selected width multiplied by the factor that is indicated when the stencil is displayed. The stitch length does not fall below the programmed minimum.

Stencil height



-80 - 800 %

This parameter changes the proportions of the stencil. An input of 0 retains the height-to-width ratio.

Stencil shift



0 - 100 %

Enter the relative displacement of the stencils here.

Basic rhythm of stencil

Basic rhythm



0 - 8, 9

See Rhythm

Step length basic rhythm 1 - 8



1 - 127 1/10 mm

Set the step length of the running stitch lines for the basic rhythm here.

Max. step length basic rhythm 9



1 - 127 1/10 mm

Enter the maximum stitch length for casual stitch division here.

Min. step length basic rhythm 9



1 - 127 1/10 mm

Enter the minimum stitch length for casual stitch division here.

Parameter Program Curved Stepstitch Fill

General information concerning parameters sets is contained under [Parameter set](#).

General parameters

Max stitch length



1 - 127 1/10 mm

Enter the maximum stitch length for casual stitch division here. The different stitch lengths prevent unwanted furrows in the embroidery. A uniform stitch length is obtained if both values are the same. Note, however, that the *stitch shortening* parameter for automatically shortened stitches can change the stitch length in tight curves.

Min stitch length



1 - 127 1/10 mm

Enter the minimum stitch length for casual stitch division here.

No. of runs

1 - 3

Enter the repetition of all running stitch lines here. The parameters can be set for each individual run of a line.

Stitch shortening

0 - 70 %

In tight curves, the program will try to shorten the stitch lengths within the scope of the shortening factor entered by you to allow optimum curve execution even in these narrow areas. If you enter, the stitches will not be shortened even in the narrow sections of the curve.

Turn parameters**Turn**

The program approaches the two adjacent points on the design contour and links them with a stitch. Since these two points are generally located very close together, the stitch length may fall below the set minimum at this point.



The second type of turn is a mixture of the previous two. A single point is generated from the last subdivision.

**Min. stitch length**

1 - 127 1/10 mm

The program will not generate any stitches that are shorter than the value entered here. Critical stitches of this kind occur only at the caps when passing from one running stitch line to the next.

Run 1 - 3**Swing**

0 - 99 1/10 mm

This parameter sets the distance of the stitch insertion (lateral deflection) from the normal running stitch line.

Shift

1 - 3

This parameter sets the shift of the insertion points with reference to the normal running stitch line.

1 = No effect on the insertion point.



2 = Offsets the insertion point by 1/2 stitch length.



3 = Offsets the insertion point by 1/3 stitch length.

**Repeat**

1, 3, 5, 7, 9

This parameter specifies how many times each stitch is to be executed. With a repeat of greater than 1, the turn type is set to type 1.

Parameter Program Cross stitch

General information on parameter sets is contained under [Parameter set](#).

General parameters**Repeat**

1 - 5

This parameter specifies how many times each cross is to be executed.

Pull compensation

0 - 9 1/10 mm

This parameter states the displacement of the stitch towards the center of the cross to compensate for the thread tension.

No. start stitches

0 - 127 1/10 mm

At the beginning of the cross stitch program, the first cross stitch is divided into stitches of the set

length.

0 = no division

No. end stitches



0 - 127 1/10 mm

At the end of the cross stitch program, the last cross stitch is divided into stitches of the set length.

0 = no division

Swing



0 - 127 1/10 mm

The last divided cross stitch is offset with each division, so that a swing is applied.

Parameter Program Object in Areas

General information on parameter sets is contained under [Parameter set](#).

General parameters

Min stitch length



1 - 127 1/10 mm

No stitch is generated whose axial length is shorter than the minimum stitch length. We recommend the selection of a value no less than 5/10 mm and no greater than 15/10 mm.

Running stitch length



This parameter determines the length of the running stitches. Do not enter large values, but only ones between 20 and 35 1/10 mm.

Block correction

Block space



-127 to 127 1/10 mm

Enter the spacing between blocks on a line.

Line space



-127 to 127 1/10 mm

Enter the spacing between blocks from line to line.

X factor

PP

-50 - 50 %

The block is enlarged or reduced by the set factor.

0 = original size

Y factor

PP

-50 - 50 %

The block is enlarged or reduced by the set factor.

0 = original size

Block position

Shift



0 - 99 %

The blocks are shifted in each line by the stated percentage.

Direction

One row forwards and one row back



Each row in the same direction



Mirror

Mirror off



Mirror on



Parameter Program Step-Lines

General information on parameter sets is contained under [Parameter set](#).

General parameters

No. of runs

1 - 3

Enter the repetition of all running stitch lines here. The parameters can be set for each individual run of a line.

Step length

1 - 127 1/10 mm

Enter the stitch length here. Note, however, that the *stitch shortening* parameter for automatically shortened stitches can change the stitch length in tight curves.

Stitch shortening

0 - 70 %

In tight curves, the program will try to shorten the stitch lengths within the scope of the shortening factor entered by you to allow optimum curve execution even in these narrow areas. If you enter, the stitches will not be shortened even in the narrow sections of the curve.

Pull compensation

0 - 999 1/10mm

The pull compensation indicates the value to be used to manipulate the stitch in order to equalize thread tension in case of branching.

Run 1 - 3**Swing**

0 - 99 1/10 mm

This parameter sets the distance of the stitch insertion (lateral deflection) from the normal running stitch line.

Shift

1 - 3

This parameter sets the shift of the insertion points with reference to the normal running stitch line.

1 = No effect on the insertion point.



2 = Offsets the insertion point by 1/2 stitch length.



3 = Offsets the insertion point by 1/3 stitch length.



Repeat



1, 3, 5, 7, 9

This parameter specifies how many times each stitch is to be executed.

Parameter Program Cross boll

General information on parameter sets is contained under [Parameter set](#).

General parameters

Type

Cross boll



Rosette



Double rosette



Laps



1 - 9

The number of laps indicates how often the cross boll is to be repeated.

Note: The repetition is visible on the screen or plot only if *Growing* is greater than 0 and/or *Shift* is selected.

Growing



1 - 100%

The *Growing* parameter states the percentage by which the cross boll diameter should increase per lap. The program is designed so that the cross boll describes the originally entered circle exactly on its last lap. The cross boll is therefore reduced accordingly before the first lap. If the repetition parameter is 1, G% has no effect.

Shift



On/Off

During each repetition the tips are shifted.

Cycle parameters Cross boll

Distance



This parameter sets the distance between the cross boll tips. If a permitted distance is entered, the number of tips is deleted.

Tips



Enter the number of tips you wish the cross boll to have here.

Cycle parameters Rosette

Tips



Enter the number of tips you wish the rosette to have here.

The program checks whether the number of tips is compatible with *Next cycle*. The number of tips must not be divisible by the cycle parameter or have a common denominator.

Next cycle



The *next cycle* forward step parameter states how many tips there are between the next stitch insertion on the circumference (of the imaginary complete rosette) and the last stitch insertion in the direction determined by the input of points x2 and x3.

Cycle parameters Double rosette

Tips



Enter the number of tips you wish the double rosette to have here.

The program checks whether the number of tips is compatible with *Next cycle*. The number of tips must not be divisible by the cycle parameter or have a common denominator.

Next cycle



The *next cycle* forward step parameter states how many tips there are between the next stitch insertion on the circumference (of the imaginary complete rosette) and the last stitch insertion in the direction determined by the input of points x2 and x3.

Previous cycle



The *previous cycle* backward step parameter states how many tips there are between the next stitch insertion on the circumference (of the imaginary complete rosette) and the last stitch insertion in the opposite direction to that determined by the input of points x2 and x3. The program automatically ensures that the 'next cycle' parameter is always greater than the 'previous cycle' parameter, i.e. the numbers are interchanged if necessary.

Parameter Program Chain up objects

General information concerning parameter sets is contained under [Parameter set](#).

General parameters

Type

The block is spread over the line without its size being changed so that the line may tail off.



The block is spread over the line and its size is changed so that the line does not tail off.



The block is spread over the line and its size is changed so that the line does not tail off and tight curves are traced better.



Mirror



The block is mirrored at the dividing vector (connection between beginning and end of block).

Min. stitch length



If the stitch inserted by the offset is shorter than the minimum stitch length, the final stitch of the block is displaced and the inserted stitch is omitted.

Block correction

Block space



- 127 - 127 1/10 mm

A stitch of the set length is added to each block. You can thus increase or decrease the block spacing.

X factor

PP

- 50 - 50 %

The block is enlarged or reduced by the set factor.

0 = original size

Y factor

PP

- 50 - 50 %

The block is enlarged or reduced by the set factor.

0 = original size

Additional parameters

Reduction only type 3



0 - 100 %

The percentage reduction specifies the maximum amount by which the block can be reduced in size. The program attempts to reduce the block within the reduction factor permitted by the user to allow the curve to be traced as well as possible, even in tight curves. If you enter 0%, the blocks are not automatically reduced, even in tight curves.

Parameter Program Object on circle

General information concerning parameter sets is contained under [Parameter set](#).

General parameters

Angle



1 - 360°

The block is repeatedly rotated through this angle. The number of blocks is arrived at automatically.

No. of parts



1 - 99

The selected block is spread round the circle n times. The angle is arrived at automatically.

Run to end



The path on the circle from the last to the first block is completed.

Mirror



The block is mirrored on the dividing vector (connection between beginning and end of block).

Stitch length



1 - 127 1/10 mm

Enter the stitch length of the running stitch line here.

Parameter Program Monogramming

This automatic program does not have a parameter set. The parameters are set individually for each object. You can determine the monogram parameters for each object. They consist of the text, character set or font, general parameters, and spacing or spreading parameters. All the settings you make in the on-screen dialog entitled *Monogram parameters* apply to the entire object. You can also set the parameters for each individual letter.

Parameter Program Monogram character

Text

You can enter the monogram text in the box provided. As an alternative when entering a text for the first time, you can write the text on the contour line; in this case, pressing [Return] terminates the entry. Corrections must be made in the input box; click the relevant location in the text in the input box and edit the incorrect characters.

Font

You can use only one font per object. Select the one you wish to use with <Left>.

General parameters

Character height



This is where you set the height of the lettering for the current object. Note that this parameter determines the basic height of the text. All the letters are enlarged or reduced on the same scale. The sizes are calculated according to the proportions of the characters determined when the font was created. It is therefore important that the relative proportions of all the characters are correct.

Character width



At 0%, the width of the character is calculated to be correct in proportion to its height. Values less than 0 create characters that are relatively narrow, and values greater than 0 characters that are relatively broad. The spacing between the characters is modified according to the set width, but only if *Spread automatically* is selected.

Character distance



You can manipulate the character spacing here. Values greater than 0 increase the spacing, and values less than 0 move the individual characters closer together. The character width is modified according to the set spacing, but only if *Spread automatically* is selected.

Stitch distance



The value set for the stitch distance applies to the entire object. All sub-objects of the characters are calculated with the set stitch distance.

Fix end



If this function is selected, the starting or fixing sequence is executed for each character; automatic thread trimming does not take place. These stitch sequences are determined within the font when the characters are defined.

Trimming



If this function is selected, the thread is trimmed after each character. The starting or fixing sequences are executed automatically.

Underlay



If this function is selected, the underlay sequence is executed for each character. The underlay is also executed in the parameter sets if switched on in the sets that are being used.

Stitch in the middle



When this function is selected, a stitch is inserted in the middle of the transition between the characters.

Spreading parameters

Spread on line



The lettering is distributed on a contour created with **Contour**. If this function is selected, you write on a horizontal line from left to right, starting from the preceding stitch. Press **[Return]** to conclude the input; only *Left-justified* is made available.

Left-justified

ABC

The lettering is left-justified on the contour on which the text is spread.

Right-justified

ABC

The lettering is right-justified on the contour on which the text is spread.

Centered

ABC

The lettering is centered on the contour on which the text is spread.

Spread automatically

A B C

The lettering is spread to utilize the full length of the contour. The character spacing is uniformly adjusted. This adjustment is also made if the width or spacing of individual characters is edited.

Parameter Program Monogram character

This on-screen dialog enables you to edit the parameters for certain characters. Select the characters for this object in the editor. The changes you make refer only to the selected characters. If *spread automatically* is selected, however, the spacing of the other characters may change as well because the lettering is always adjusted relative to the entire contour.

If only a single character is selected, all of its parameters are displayed. If several characters are selected, only the parameters whose value or status is the same for all the selected characters are displayed. If the values or statuses are different, the box remains empty or the tick is shown against a gray background. If you enter a new value in an empty box, it will be applied to all the selected characters.

If you leave the box empty, the characters retain their existing parameters.

Absolute value

Height

A I

Absolute height of the character in tenths of a millimeter.

Width

A

Absolute width of the character in tenths of a millimeter.

Left distance

Absolute spacing to the left of the character in tenths of a millimeter.

Right distance

Absolute spacing to the right of the character in tenths of a millimeter.

Percentage change of values**Height**

Percentage change of character height. A value greater than 0 makes the character taller, and a value less than 0 makes it shorter.

Width

Percentage change of character width. A value greater than 0 makes the character broader, and a value less than 0 makes it narrower.

Left distance

Percentage change of spacing to the left of the character. A value greater than 0 increases the spacing, and a value less than 0 decreases it.

Right distance

Percentage change of spacing to the right of the character. A value greater than 0 increases the spacing, and a value less than 0 decreases it.

Direction parameters**Slant**

Here you can make a character slant. Note that the angle is restricted because the characters are based on free-form curves. Excessive modifications can deform characters to the extent that they become illegible.

Base line offset

An offset is applied to character so that it appears above or below the line on which the text is spread by the set amount. The reference point is the character's base line, which is determined when the character is saved in the font.

Angle parameters

Automatic angle

If this function is selected, each character is rotated to match the curve traced by the line. When it is switched off, you can determine an angle of rotation for the character. The rotation point of a character is the intersection of its base and center lines. These are determined when the character is saved in the font.

Character angle



Here you can specify the angle of rotation for the character. The box is active only when *Automatic angle* is deselected.

Additional parameters

Fix end



If this function is selected, the starting or fixing sequence is executed for each character; automatic thread trimming does not take place. These stitch sequences are determined within the font when the characters are defined.

Trimming



If this function is selected, the thread is trimmed for each character. The starting or fixing sequences are executed automatically.

Underlay



If this function is selected, the underlay sequence is executed for each character. The underlay is also executed in the parameter sets if switched on in the sets that are being used.

Stitch in the middle



When this function is selected, a stitch is inserted in the middle of the transition to the next character.

Stitch distance ramps

A stitch distance ramp is used in satin stitch objects to set the stitch distance according to the stitch length.

Three stitch lengths play a special role in this context.

In the case of stitches whose length is less than or equal to the short stitch length, the selected stitch distance is enlarged by the set percentage. This stitch distance is known as the lower limit distance.

In the case of stitches whose length is greater than or equal to the long stitch length, the selected stitch distance is reduced by the set percentage. This stitch distance is known as the upper limit distance.

In the case of stitches whose length is between the short and medium stitch length, distances between the lower limit distance and selected stitch distance are obtained. A proportional adjustment takes place.

In the case of stitches whose length is between the medium and long stitch length, distances between the selected stitch distance and the upper limit distance are obtained. A proportional adjustment takes place.

We cannot guarantee that the stitch distance ramp you set will produce a perfect embroidery result (thread break, insufficient coverage etc.). You must therefore conduct test runs to establish which setting leads to the best result with specific materials.

Editing stitch distance ramps

In the main menu click *Parameter settings* and then *Ramps*.

The top part of the on-screen dialog contains a graphic overview of the existing stitch distance ramps. The top row shows the system ramps, and the bottom row the ramps used in the design. The scroll buttons enable you to scroll to the left and right because only 8 ramps can be graphically depicted at once. In the bottom part of the display you can execute the desired action with the available buttons. Exit the dialog by pressing *Close*.

In the input mask click the boxes you wish to edit and enter the desired value.

Press *Save* to save the ramp. Select a ramp memory location with *<Left>*. If the location has already been assigned, it will be overwritten if you respond to the safety inquiry with *Yes*.

If you edit a design ramp, the design has to be recalculated.

Deleting stitch distance ramps

To delete a stitch distance ramp, click *<Left>* on *Delete*. Then select the ramp you wish to delete with *<Left>*; only the system ramps can be selected. If they are not used in the design, design ramps are automatically deleted when the design is saved. Use *Cancel* to exit the delete operation without deleting a ramp.

Stencil

A stencil is an individual stitch rhythm that can be used with comfort fill (program 10). A stencil is comparable with a group of dividing lines that is repeated over the entire running stitch area. Stitches are created at the intersections between the dividing lines of the stencils and the running stitch lines.

The frame around the dividing lines describes the outer edge of the stencil. The dividing lines need not necessarily be located inside the frame. The stencils can also be moved towards each other with the aid of a parameter in the *Parameterset Program Stepstitch*.

The top part of the on-screen dialog contains a graphic overview of the existing stencils. The top row shows the system stencils, and the bottom row the stencils used in the design. The scroll buttons enable you to scroll to the left and right because only 8 stencils can be graphically depicted at once. In the bottom part of the display you can execute the desired action with the available buttons. Exit the dialog by pressing *Close*.

Editing a stencil

Click a stencil box; the on-screen dialog is closed. Follow the instructions issued by the assistant.

Once you have finished editing, click *<Left>* on a stencil box. If you select an empty box, the stencil is copied to the box. If the box is already occupied by a stencil, a further on-screen dialog asks if you

wish to overwrite the selected stencil with the one you have just edited. Instead of selecting a stencil box, you can exit this operation by clicking <Left> on *Cancel*.

Creating a stencil

Click <Left> on *New*; the on-screen dialog is closed and you can start to create a new stencil. First create a frame by determining diagonally opposite corners with <Left>. Then create the contour lines (see *Contour*). Confirm the new stencil with [Return].

Once you have created a stencil, you can edit it in the same way as an existing one (see "Editing a stencil").

Deleting a stencil

To delete a stencil, click <Left> on *Delete*. Then select the stencil you wish to delete by clicking <Left> on one of the stencil boxes; only the system stencils can be selected. If they are not used in the design, design stencils are automatically deleted when the design is saved. Instead of selecting a stencil box, you can exit this operation by clicking <Left> on *Cancel*.

Stitch sequence

A stitch sequence is an individual series of stitches that is used by SATIN STITCH WITH FREE STITCH SEQUENCES (program 6).

The top part of the on-screen dialog contains a graphic overview of the existing stitch sequences. The top row shows the system stitch sequences, and the bottom row the stitch sequences used in the design. The scroll buttons enable you to scroll to the left and right because only 8 stitch sequences can be graphically depicted at once. In the bottom part of the display you can execute the desired action with the available buttons. Exit the dialog by pressing *Cancel*.

Editing a stitch sequence

Click a stitch sequence box; the on-screen dialog is closed. Follow the instructions issued by the assistant.

Once you have finished editing, click <Left> on a stitch sequence box. If you select an empty box, the stitch sequence is copied to the box. If the box is already occupied by a stitch sequence, a further on-screen dialog asks if you wish to overwrite the selected stitch sequence with the one you have just edited. Instead of selecting a stitch sequence box, you can exit this operation by clicking <Left> on *Cancel*.

Creating a stitch sequence

Click <Left> on *New*; the on-screen dialog is closed and the on-screen dialog *Parameter Stitch sequence* for creating the parameters for a stitch sequence appears.

On completion of this dialog, you can start to create a new stitch sequence. Follow the instructions issued by the assistant.

Once you have created a stitch sequence, proceed as you would after editing an existing stitch sequence (see "Editing a stitch sequence").

Deleting a stitch sequence

To delete a stitch sequence, click <Left> on *Delete*. Then select the stitch sequence you wish to delete by clicking <Left> on one of the stitch sequence boxes; only the system stitch sequences can be selected. If they are not used in the design, design stitch sequences are automatically deleted when the design is saved. Instead of selecting a stitch sequence box, you can exit this operation by clicking <Left> on *Cancel*.

Parameter Stitch sequence

This on-screen dialog allows you to determine the parameters for a stitch sequence. If you wish to edit the parameters for an existing stitch sequence, you can edit only the overlap. When creating the parameters for a new stitch sequence, all the options provided by this dialog are available.

Use *Cancel* to close the dialog without accepting the parameter settings. Pressing *OK* also closes the dialog, but the parameter settings are accepted in this case. Only correct values that are within the validity range are accepted.

Main parameters for creating a stitch sequence

Number of stitches

State the number of stitches over which the sequence is to extend.

Overlap

State the number of stitches over which the sequence is to overlap.

Stitch sequence type

- 1: Both outlines
- 3: In addition to the two outlines, a maximum of three percentage divided lines
- 5: In addition to the two outlines, a user-selected number of lines
- 8: In addition to the two outlines, two lines with fixed spacing

Additional parameters for the stitch type

Parameters for the set type:

- 1: No parameters
- 3: Maximum of three percentages
- 5: Number of lines
- 8: Spacing in 1/10 mm

Parametersatz Design

Die Parametersatzdialoge für Designautomatiken bestehen aus zwei Teilen. Der obere Teil enthält die Parameter, die objektübergreifend sind, s. [Parametersatz](#). Der untere Teil enthält objektbezogene Parameter. Diese sind **nicht** Bestandteil der Parametersätze. Es handelt sich bei diesen Parametern um Objektgrößen z.B. um die Objekthöhe.

Im Vorschaufenster können Sie die Einstellung der Parameter direkt überprüfen. Nach jedem Ändern eines Parameters wird das Vorschauobjekt neu kalkuliert.

Border

General information concerning parameter sets is contained under [Parameter set](#).

Parameter set parameters

Automatic corner



Here you can determine whether the corners of the object are to be formed automatically.

Rotate in corner



Here you can determine whether the stitches are to be rotated before or after a corner. The effect is to create a continuous transition from a vertical stitch direction marker to the corner stitch direction marker and back.

No. of runnings



0 - 10

This parameter determines how many times the underlay is to be executed. If the parameter is greater than 0, the number of underlays is output at the start of the object.

Running stitch length



1 - 99 1/10 mm

Enter the step lengths of the underlays here.

Object parameters

Border width



0.1-999 mm

Enter border width here.

Stitch distance



0.1-99 1/10mm

Enter the stitch distance here.

Colors



Pressing *Colors* initiates a dialog that enables you to set the *Colors* of the object.

Double border

General information concerning parameter sets is contained under *Parameter set*.

Parameter set parameters

Automatic corner



Here you can determine whether the corners of the object are to be formed automatically.

Rotate in corner



Here you can determine whether the stitches are to be rotated before or after a corner. The effect is to create a continuous transition from a vertical stitch direction marker to the corner stitch direction marker and back.

No. of runnings

1..n

0 - 10

This parameter determines how many times the underlay is to be executed. If the parameter is greater than 0, the number of underlays is output at the start of the object.

Running stitch length



1 - 99 1/10 mm

Enter the step lengths of the underlays here.

Object parameters

Proportional

Y=X

Here you can determine whether the two borders are to have the same width. If the option is selected, the second value is automatically edited to comply with the first.

Border width 1



0.1 - 999 mm

Enter border width 1 here.

Border width 2



0.1 - 999 mm

Enter border width 2 here.

Stitch distance



0.1 - 99 1/10 mm

Enter the stitch distance here.

Colors



Pressing *Colors* initiates a dialog that enables you to set the *Colors* of the object.

Bohrstaffel

General information concerning parameter sets is contained under *Parameter set*.

Parameter set parameters

Number of stitches



Enter the number of stitches here.

No. of runnings

1..n

0 - 10

This parameter determines how many times the underlay is to be executed. If the parameter is greater than 0, the number of underlays is output at the start of the object.

Running stitch length



1 - 99 1/10 mm

Enter the step lengths of the underlays here.

Object parameters

Object height



Enter the object height here.

Object width



Enter the object width here.

Width



0.1 - 999 mm

Enter the border width here.

Stitch distance



0.1 - 99 1/10 mm

Enter the stitch distance here.

Colors



Pressing *Colors* initiates a dialog that enables you to set the *Colors* of the object.

Zugstuffel

General information concerning parameter sets is contained under *Parameter set*.

Parameter set parameters

Number of stitches



Enter the number of stitches here.

No. of runnings

1..n

0 - 10

This parameter determines how many times the underlay is to be executed. If the parameter is greater than 0, the number of underlays is output at the start of the object.

Running stitch length



1 - 99 1/10 mm

Enter the step lengths of the underlays here.

Object parameters

Object height



Enter the object height here.

Object width



Enter the object width here.

Border width



0.1-999 mm

Enter border width here.

Stitch distance



0.1-99 1/10mm

Enter the stitch distance here.

Aufteilungslinie



50-100%

Die Position der Aufteilungslinie stellen Sie hier ein. Mit ihr können Sie festlegen, wo die Objektbreite gemessen werden soll. Bei 50% wird in der Mitte gemessen. Bei 100% wird am Ende der Beine gemessen.

Spiegeln



Hier legen Sie fest, ob die Beine an der Grundlinie gespiegelt werden sollen.

Colors



Pressing *Colors* initiates a dialog that enables you to set the *Colors* of the object.

Double zugstüffel

General information concerning parameter sets is contained under *Parameter set*.

Parameter set parameters

Number of stitches



Enter the number of stitches here.

No. of runnings



0 - 10

This parameter determines how many times the underlay is to be executed. If the parameter is greater than 0, the number of underlays is output at the start of the object.

Running stitch length



1 - 99 1/10 mm

Enter the step lengths of the underlays here.

Object parameters

Object height



Enter the object height here.

Object width



Enter the object width here.

Colors



Pressing *Colors* initiates a dialog that enables you to set the *Colors* of the object.

Zughöhl

General information concerning parameter sets is contained under *Parameter set*.

Parameter set parameters

Number of stitches



Enter the number of stitches here.

No. of runnings

1..n

0 - 10

This parameter determines how many times the underlay is to be executed. If the parameter is greater than 0, the number of underlays is output at the start of the object.

Running stitch length



1 - 99 1/10 mm

Enter the step lengths of the underlays here.

Object parameters

Object height



Enter the object height here.

Object width



Enter the object width here.

Colors



Pressing *Colors* initiates a dialog that enables you to set the *Colors* of the object.

Bohrhöh

General information concerning parameters sets is contained under *Parameter set*.

Parameter set parameters

No. stitches vert [1/2]



Enter the number of vertical stitches here.

No. stitches hor [1/2]



Enter the number of horizontal stitches here.

Drawing cross



This option determines whether a cross is to be drawn where the grid lines intersect.

Object parameters

Object height



Enter the object height here.

Object width



Enter the object width here.

Angle of rotation



Enter the orientation angle of the grid here.

Colors



Pressing *Colors* initiates a dialog that enables you to set the *Colors* of the object.

Wabenhöhl

General information concerning parameter sets is contained under *Parameter set*.

Parameter set parameters

Schenkelverhältnis



Die Verhältnis Objekthöhe zu Schenkelhöhe stellen Sie hier ein.

No. stitches vert



Enter the number of vertical stitches here.

No. stitches hor



Enter the number of horizontal stitches here.

Mittelkreuz



Hier können Sie festlegen, ob im Mittelpunkt der Wabe ein Kreuz gezeichnet werden soll.

Object parameters

Object height



Enter the object height here.

Object width



Enter the object width here.

Angle of rotation



Enter the orientation angle of the grid here.

Colors



Pressing *Colors* initiates a dialog that enables you to set the *Colors* of the object.

Ziegelhöhl

General information concerning parameter sets is contained under *Parameter set*.

Parameter set parameters

No. stitches vert



Enter the number of vertical stitches here.

No. stitches hor



Enter the number of horizontal stitches here.

Mittelkreuz



Hier können Sie festlegen, ob im Mittelpunkt einer Zelle ein Kreuz gezeichnet werden soll.

Object parameters

Object height



Enter the object height here.

Object width

Enter the object width here.

Angle of rotation

Enter the orientation angle of the grid here.

Colors

Pressing *Colors* initiates a dialog that enables you to set the *Colors* of the object.

Stoffhöh

General information concerning parameter sets is contained under *Parameter set*.

Parameter set parameters**No. stitches [1/2]**

Enter the number of vertical stitches here.

Object parameters**Object height**

Enter the object height here.

Object width

Enter the object width here.

Angle of rotation

Enter the orientation angle of the grid here.

Colors

Pressing *Colors* initiates a dialog that enables you to set the *Colors* of the object.

Grid filling

General information concerning parameter sets is contained under *Parameter set*.

Parameter set parameters

Only horizont. lines



Only horizontal grid lines are calculated.

Only grid lines



Only sloping grid lines are calculated.

Grid + horizont. lines



Sloping and horizontal grid lines are calculated.

Center position



Here you determine whether the horizontal grid lines are to pass centrally between the intersecting points of the sloping grid lines.

Intersect position



Here you determine whether the horizontal grid lines are to pass through the intersecting points of the sloping grid lines.

Rhythm



Here you set the number of stitches on the sloping grid lines from the top left to the bottom right.

Rhythm



Here you set the number of stitches on the sloping grid lines from the bottom left to the top right.

Rhythm



Enter the number of stitches on the horizontal grid lines here.

Object parameters

Object height



Enter the object height here.

Object width



Enter the object width here.

Angle of rotation



Enter the orientation angle of the grid here.

Colors



Pressing *Colors* initiates a dialog that enables you to set the *Colors* of the object.

Bored hole

General information concerning parameter sets is contained under *Parameter set*.

Parameter set parameters

No. of runnings

1..n

0 - 10

This parameter determines how many times the underlay is to be executed. If the parameter is greater than 0, the number of underlays is output at the start of the object.

Running stitch length



1 - 99 1/10 mm

Enter the step lengths of the underlays here.

Object parameters

Diameter



0.1 - 999 mm

Enter the diameter of the bored hole here.

Width



0.1 - 999 mm

Enter the border width here.

Stitch distance



0.1 - 99 1/10 mm

Enter the stitch distance here.

Colors



Pressing *Colors* initiates a dialog that enables you to set the *Colors* of the object.

Birnenloch

General information concerning parameter sets is contained under *Parameter set*.

Parameter set parameters

Automatic corner



Here you can determine whether the corners of the object are to be formed automatically.

Rotate in corner



Here you can determine whether the stitches are to be rotated before or after a corner. The effect is to create a continuous transition from a vertical stitch direction marker to the corner stitch direction marker and back.

No. of runnings



0 - 10

This parameter determines how many times the underlay is to be executed. If the parameter is greater

than 0, the number of underlays is output at the start of the object.

Running stitch length



1 - 99 1/10 mm

Enter the step lengths of the underlays here.

Object parameters

Object height



Enter the object height here.

Object width



Enter the object width here.

Width



0.1 - 999 mm

Enter the border width here.

Stitch distance



0.1 - 99 1/10 mm

Enter the stitch distance here.

Colors



Pressing *Colors* initiates a dialog that enables you to set the *Colors* of the object.

Rectangle bored hole

General information concerning parameter sets is contained under *Parameter set*.

Parameter set parameters

Automatic corner



Here you can determine whether the corners of the object are to be formed automatically.

Rotate in corner

Here you can determine whether the stitches are to be rotated before or after a corner. The effect is to create a continuous transition from a vertical stitch direction marker to the corner stitch direction marker and back.

No. of runnings

0 - 10

This parameter determines how many times the underlay is to be executed. If the parameter is greater than 0, the number of underlays is output at the start of the object.

Running stitch length

1 - 99 1/10 mm

Enter the step lengths of the underlays here.

Object parameters**Object height**

Enter the object height here.

Object width

Enter the object width here.

Width

0.1 - 999 mm

Enter the border width here.

Stitch distance

0.1 - 99 1/10mm

Enter the stitch distance here.

Colors

Pressing *Colors* initiates a dialog that enables you to set the *Colors* of the object.

Schneidloch

General information concerning parameter sets is contained under [Parameter set](#).

Parameter set parameters

Automatic corner



Here you can determine whether the corners of the object are to be formed automatically.

Rotate in corner



Here you can determine whether the stitches are to be rotated before or after a corner. The effect is to create a continuous transition from a vertical stitch direction marker to the corner stitch direction marker and back.

No. of runnings



0 - 10

This parameter determines how many times the underlay is to be executed. If the parameter is greater than 0, the number of underlays is output at the start of the object.

Running stitch length



1 - 99 1/10 mm

Enter the step lengths of the underlays here.

Object parameters

Object height



Enter the object height here.

Object width



Enter the object width here.

Border width



0.1-999 mm

Enter border width here.

Stitch distance



0.1-99 1/10mm

Enter the stitch distance here.

Colors



Pressing *Colors* initiates a dialog that enables you to set the *Colors* of the object.

Cross boll

see *Parameter Cross boll*

Steplinie

s. *Parameter Stepstichlinie*

Selection manager needle design/standard text/head selection

This dialog serves two main purposes:

Fast selection of a needle design (head selection, standard text) from the system or the design when punching.

Selection of needle designs (head selections, standard texts) from the system or the design for further modification of parameter settings.

Short cut

There are two ways of executing a short cut:

You can enter the number of the needle design (head selection, standard text) directly in the number input box labeled **Number**. The number refers to the entries in the design. If you enter a number that is not contained in the design, but exists in the system, the relevant needle design (head selection, standard text) is copied from the system to the design once it is confirmed. An entered number that is not contained in either the system or the design cannot be confirmed.

You can select an entry from the system or design column with `<Left>`.

Confirm the selected needle design (head selection, standard text) with either `[Return]` or *OK*. Once the selection has been confirmed, the dialog closes.

Select

You can select needle designs (head selections, standard texts) with `<Left>` on a single entry or `[Shift] + <Links>` on several entries in either the system or the design column.

New

This button masks the dialog and opens another one in which you can create a new needle design

(head selection, standard text). Once the called dialog is closed, the masked one reopens.

Change

This button masks the dialog and opens another one in which you can edit the selected needle design (head selection, standard text). Once the called dialog is closed, the masked one reopens.

View

This button masks the dialog and opens another one in which you can view the selected needle design (head selection, standard text). Once the called dialog is closed, the masked one reopens.

Copy

This button copies the selected needle designs (head selections, standard texts) from the source to the destination; in other words, from the system to the design, and from the design to the system.

Delete

This button deletes the needle designs (head selections, standard texts) selected in the system.

Save

This button accepts the executed modifications and closes the dialog.

Cancel

This button rejects the executed modifications and closes the dialog.

Needle designs

This dialog allows you to view and program needle designs.

General principle:

Clicking <Left> on one of the numbered buttons selects the relevant needle design. The data relating to the needle design are displayed in a series of fields. Thereafter the individual needles can be selected and deselected by clicking <Left> on the relevant buttons.

Repeat display

Basic repeat

This field is for information purposes only; it shows the basic repeat set in the **Design head**.

Color repeat

This field is for information purposes only; it shows the color repeat set in the **Design head**.

Max. repeat

This field is for information purposes only; it shows the maximum repeat set in the **Design head**.

Needle design data

Needle design number

This input box indicates the number of the selected needle design.

Needle design name

This input box indicates the name of the selected needle design.

Infinite No. of needles

This button indicates whether the number of needles is to be regarded as restricted or unrestricted for the selected needle design.

No. of needles

This box indicates the number of needles for the selected needle design. The number of needles can be entered if the "Infinite No. of needles" button is not set.

Color reset upon maximum repeat

Use this button to determine whether a color reset is to be performed in the color assignment of the individual needles after the maximum repeat. The effect of the color reset is as follows: the first needle after the maximum repeat is assigned the first color of the color repeat; in other words, the color repeat starts again with this needle. If a color reset is not performed, the needles are consecutively assigned the colors of the color repeat.

Selection aids**All on**

This button selects all the needles of the chosen needle design.

All off

This button deselects all the needles of the chosen needle design.

Invert

This button switches on all the deselected needles and switches off all the selected needles.

Repeat

This button repeats the needle selection assignment, starting with the first needle in either the basic repeat, the maximum repeat, or in a defined block size, which you enter in a box. Select the type of repetition with the relevant buttons.

New needle design

This button creates a new needle design. Its number is calculated automatically depending on the first unassigned number, starting with the start number.

Scroll bars

You can use the horizontal and vertical scroll bars to move the visible area of the needle designs.

OK

This button accepts the inputs and closes the dialog.

Cancel

This button rejects the inputs and closes the dialog.

Head selection

This dialog allows you to view and program head selections.

General principle:

Clicking <Left> on one of the numbered buttons selects the relevant head selection. The data

relating to the head selection are displayed in a series of fields. Thereafter the individual heads can be selected and deselected by clicking <Left> on the relevant buttons.

Head selection data

Head selection number

This input box indicates the number of the selected head selection.

Head selection name

This input box indicates the name of the selected head selection.

No head limit

This button indicates whether the number of heads is to be regarded as restricted or unrestricted for the selected head selection.

No. of heads

This box indicates the number of heads for the selected head selection. The number of heads can be entered if the "No head limit" button is not set.

Selection aids

All on

This button selects all the heads of the chosen head selection.

All off

This button deselects all the heads of the chosen head selection.

Invert

This button switches on all the deselected heads and switches off all the selected heads.

Repeat

This button repeats the head selection assignment, starting with the first head in a defined repeat, which you enter in a box.

New head selection

This button creates a new head selection. Its number is calculated automatically depending on the first unassigned number, starting with the start number.

Scroll bars

You can use the horizontal and vertical scroll bars to move the visible area of the head selections.

OK

This button accepts the inputs and closes the dialog.

Cancel

This button rejects the inputs and closes the dialog.

Textbaustein

Dieser Dialog dient zur Neueingabe und zum Ändern eines Textbausteins.

Textnummer

Mit diesem Zahleneingabefeld können Sie die Nummer des Textbausteins ändern.

Name

In diesem Textfeld können Sie den Namen des Textbausteins eingeben, welcher der ersten Zeile des Textes entspricht.

Text

In diesem Texteingabefeld können Sie den Text schreiben. Hierbei erzeugt die Eingabetaste eine neue Zeile, wenn der Textcursor sich innerhalb des Texteingabefeldes befindet.

Schließen

Dieser Knopf beendet den Dialog ohne die vorgenommenen Eingaben zu übernehmen.

Speichern

Dieser Knopf beendet den Dialog mit Übernahme der vorgenommenen Eingaben, sofern die Textbausteinnummer gültig ist.

Programmierung Sonderfunktionsanzeige

Mit diesem Dialog können Sie bestimmen, welche der Sonderfunktionen im Assistenten (Schiffli SF-Status) angezeigt werden sollen. Es sind maximal 9 Sonderfunktionen möglich.

Dieser Dialog umfasst zwei Aufgaben (Modi):

- Setzen einer Sonderfunktion in eines der Anzeigefelder
- Löschen einer Sonderfunktion aus dem Anzeigefeld

Setzen einer Sonderfunktion

Dazu wählt man mit [<Links>](#) auf einen der belegten Sonderfunktionsfelder (Sonderfunktionsknöpfe) eine Sonderfunktion aus. Das Symbol dieser Sonderfunktion erscheint als Kontrolle auf dem Feld neben den Anzeigefeldern. Wählt man danach eine andere Sonderfunktion, so wird das Symbol dieser anderen Sonderfunktion auf dem Kontrollfeld angezeigt.

Mit [<Links>](#) auf eines der 9 Anzeigefelder wird die zuletzt gewählt Sonderfunktion für die Anzeige programmiert. Hierbei ist es möglich, schon belegte Felder auszuwählen.

Löschen

Mit diesem Knopf wird der Löschmodus gestartet.

Abbrechen

Mit diesem Knopf wird der Dialog beendet und die Programmierung wird verworfen.

OK

Mit diesem Knopf wird der Dialog beendet und die Programmierung übernommen.

Löschen einer Sonderfunktion

Den Löschmodus startet man mit <Links> auf *Löschen*. Danach können Sie entweder mit <Links> auf eines der Anzeigefelder (Anzeige­knöpfe) die zu löschende Sonderfunktion auswählen, welche dann aus der Menge herausgenommen wird. Danach ist der Löschmodus beendet. Oder Sie Beenden den Löschmodus direkt mit <Links> auf *Abbrechen*.

Punching

During punching the standard screen display is laid out as follows:

- Left, current image section (1)
- Top right, overview window (2)
- Right, assistant bar (3)
- Bottom, display of softkey function (4)

Current image section

The current image section contains the reference and stitch data for the design you are currently punching. If so wished, you can also display the relevant drawing and/or the scanned image.

For further information, see section [General functions](#)

The window can be moved (scrolled) by moving the cursor (crosshairs) to the edge of the display with the mouse, or by using the cursor keys.

Overview window

The overview window contains the complete design. The current image section is outlined in the overview window.

Assistant bar

The bar indicates the enlargement factor (zoom), number of stitches contained in the design, preselected automatic program, status of the special functions and, at the bottom right, the relative position of the cursor (distance from previous input) and other information.

Display of softkey functions

The relevant assignment of the softkeys [F1] to [F12] is indicated at the bottom left of the screen.

Manual punching

Manual punching is understood to mean all paths entered with the left mouse button, special functions entered with [F12] ([Special functions](#)), changes to the maximum stitch length with [*] ([Maximum stitch length](#)) and the setting of markers with [Div] ([Set markings](#)). Keys [*] and [Div] are part of the number keypad.

The following functions are also available:

Block function



Press [F3] to start the [Block function](#).

Point/Corner/Straight Line

Press [F6] to start the Editor.

Drawing

[F8] initiates Drawing functions

Initiation of an object without selection of program type

[F10] initiates a new object (current automatic program) Automatic programs

Initiation of an object with selection of program type

[F11] initiates a new object (with selection of program type) Automatic programs

Insert a special function

[F12] inserts a Special function

Caution

Some functions are not available in the editor's insert mode. These are block, editor and initiation of the drawing functions.

Manual stitches

Two points (x1, x2) entered by clicking <Left> are linked by a stitch (manual stitch). In many cases, the first point (x1) is an end point of an automatic program. This is the simplest way of recording stitches. A jump stitch (no needle insertion at the end of the travel path) is generated with [Ctrl] + <Left>.

All automatic programs begin at the last entered manual stitch or end point of the previous program.

[Delete] deletes the last manual stitch or, in conjunction with an object, calls the editor.

Sonderfunktionen

Sonderfunktionen Multi-Head

Sonderfunktionen Schiffli

Special functions Multi-Head

In the on-screen dialog for special functions you can specify a special function by clicking the symbol or entering the relevant number. The number is indicated underneath the symbol.

Press [Esc] to exit the input of special functions without triggering any action.

Functions that are not available in this part of the design are highlighted in gray.

List of special functions

No.	Function	Cornelly on	Cornelly off
1-32	Needle change to needle 1-32	X	X
40	Stop function	X	X
42	Boring function on		X
43	Thread trimming	X	X
45	Cord on		X
46	Loop on		X
47-49	Chain/moos/coil (Cornelly)	X	
50	1st sequin on		X
51	2st sequin on		X
52	Head selection		X
53	Repeat jump		X
60	Jump stitch to start point	X	X
61	Jump stitch to start point and Change to start needle	X	X
62	Change to start needle	X	X
70	Reserve 0-9	X	X

Automatic needle change (SF 1-32)



This function generates an automatic needle change in the reference data. The program does not allow a change to the needle that is already active or the input of several needle changes at the same position.

Stop function (SF 40)



Input this special function number to record a stop in the reference data.

Borer (SF 42)



Special function 42 selects the borer. Enter the boring positions with <Left>. When [Strg] + <Links> is pressed, the borer moves to the appropriate position but does not bore into the material. The automatic jump stitch and maximum stitch length functions are also valid for the boring paths.

Jump stitches are executed with the stitch length stated in the design head if the current stitch length is less than or equal to 10 1/10 mm.

When the borer is switched off, the automatic jump stitch function is switched on and the maximum stitch length is set to the design head stitch length if the current stitch length is less than or equal to 10

1/10 mm.

The 'Borer' function is available when *Cornelly* is deselected in the design head.

Thread trimming (SF 43)



Special function 43 trims the thread.

In conjunction with output on diskette or tape punch, thread trimming can be set to *no*. All thread trimming functions in the reference data are then ignored and are consequently not output in the stitch data. Thread trimming does not have to be set with an automatic needle change because the trimming function is executed automatically during output if thread trimming is switched on.

Cord (SF 45)



Special function 45 switches on the cord. This function primarily serves to provide information. The puncher must make sure that the needle with the cord facility is active and should record this in the design head. The 'Cord' function is available when *Cornelly* is deselected in the design head.

Loop (SF 46)



Special function 46 switches on the loop. This function primarily serves to provide information. The puncher must make sure that the needle with the loop facility is active and should record this in the design head.

The 'Loop' function is available when *Cornelly* is deselected in the design head.

Chain, moos and coil (SF 47- SF 49)

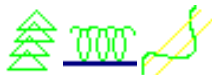

These functions are available when *Cornelly* is selected in the design head.

Sequin (SF 50/51)



Special functions 50 and 51 switch on the 1st and 2nd sequins. A sequin is then inserted at each manual stitch identified by <Left><Left>. The sequin is represented by a circle on the screen. Press :SF: again to deselect the sequin function again.

The 'Sequin' function is available when *Cornelly* is deselected in the design head.

Head selection (SF 52)



This special function is available if *Repeat* is selected in the design head. After the selection of the head selection, the EPC system calculates the appropriate repeat jump and proposes the associated value. Either accept this value or enter a different one. (*Head selection*)

Then state the operating location of the first active head or needle

Repeat jump (SF 53)



This special function is available if *Repeat* is selected in the design head. It shifts the work (pantograph) by x heads to the left or right.

Jump stitch to start point (SF 60)



Special function 60 effects a jump stitch from the last input point exactly to the start point. If you subsequently change the start point, the jump stitch to start point is also changed. If thread trimming is switched with stitch data output on diskette or punched tape, the thread is trimmed before the jump stitch to start point

Jump stitch to start point with change to start needle (SF 61)



From the last point that is entered, special function 61 generates a jump stitch exactly to the start point and changes to the start needle. If you subsequently change the start point or start needle in the design head, the jump stitch to start point and change to start needle setting are also changed.

Change to start needle (SF 62)



From the last point that is entered, special function 62 generates a change to the start needle. If you subsequently change the start needle in the design head, the change to start needle settings are also changed.

Reserve (SF 70)



Once you have entered special function number 70, you also have to state the reserve number. Ten reserve numbers (0 - 9) are available. You can insert each reserve number in a design as often as you wish.

When the data are output to a diskette or the tape punch, you make a reserve allocation to indicate which code has to be output for this function. (Disk)

Caution

The reserve function is envisaged for external code functions (Tajima or Barudan); it enables you to output functions with which we are not familiar.

Automatic jump stitch



The automatic jump stitch function is selected (ON) and deselected (OFF).

With the automatic jump stitch function selected (SA green), the stitches that are longer than the currently active maximum stitch length are divided into a series of jump stitches and one end stitch.

With the automatic jump stitch function deselected (SA red), the stitches that are longer than the maximum stitch length are divided into single stitches.

The division is carried out symmetrically.

Setting the automatic jump stitch function to OFF simplifies boring function inputs by obviating the need to input each boring position on a straight line. Simply set the maximum stitch length to the appropriate value (spacing between boring points), deselect the automatic jump stitch function and

input the end of the straight line with `<Left>`.

The automatic jump stitch function is for manual stitches and borer paths only.

Sonderfunktionen Schiffli

In dem Sonderfunktionsdialog können Sie Sonderfunktionen mit `<Links>` auf das Symbol auswählen. Einige Sonderfunktionen haben eine Ein-/Aus-Funktionalität, einige haben Parameterwerte. Unter den Symbolen wird bei den Funktionen mit Parameterwerten der Parameterwert angezeigt, bei den Funktionen mit Ein-/Aus-Funktionalität wird durch „1“ der Zustand „Ein“, durch „0“ der Zustand „Aus“ repräsentiert. Die Symbole mit Ein-/Aus-Funktionalität sind beim Zustand „Aus“ mit einem roten Kreuz versehen.

Nadelrolle



Diese Sonderfunktion schaltet die Nadelrolle ein bzw. aus.

Rapport



Bei Wahl dieser Funktion wird ein weiterer [Dialog zur Auswahl einer Nadelmusterschaltung](#) aufgerufen.

Rapportsprung



Bei dieser Sonderfunktion können Sie einen Parameterwert eingeben.

Schnurhebel



Diese Sonderfunktion schaltet den Schnurhebel ein bzw. aus.

Paillette



Diese Sonderfunktion schaltet die Paillette ein bzw. aus.

Schnellgang



Diese Sonderfunktion schaltet den Schnellgang ein bzw. aus.

Touren



Bei dieser Sonderfunktion können Sie die Anzahl der Touren als Parameter festlegen.

Bohrer



Diese Sonderfunktion schaltet den Bohrer ein bzw. aus.

Bohrtiefe



Bei dieser Sonderfunktion können Sie die Bohrtiefe als Parameter festlegen.

Bohrrolle



Diese Sonderfunktion schaltet die Bohrrolle ein bzw. aus.

2. Bohrer



Diese Sonderfunktion schaltet den 2. Bohrer ein bzw. aus.

Maximale Stichlänge



Mit dieser „Sonderfunktion“ bestimmen Sie die maximale Stichlänge. Hierzu wird ein weiterer Dialog zur Eingabe der maximalen Stichlänge aufgerufen.

Sperrzeug



Diese Sonderfunktion schaltet das Sperrzeug ein bzw. aus.

Fadenbremse



Mit dieser Sonderfunktion können Sie den Wert für die Fadenbremse als Parameter festlegen.

Großer Fadenleiter



Mit dieser Sonderfunktion legen Sie den Wert des großen Fadenleiters als Parameter fest.

Kleiner Fadenleiter



Mit dieser Sonderfunktion legen Sie den Wert des kleinen Fadenleiters als Parameter fest.

Textbaustein

Text

Bei Wahl dieser Sonderfunktion wird ein weiterer [Dialog zur Auswahl eines Textbausteines](#) aufgerufen.

Stop



Bei Wahl dieser Sonderfunktion ist ein Stopp in den Referenzdaten abgelegt.

Fadenschnitt



Diese Sonderfunktion löst einen Fadenschnitt aus.

Maximum stitch length

The maximum stitch length can be altered only to a length that is shorter than the maximum stitch length in the design head. Input [*] first (on the number keypad of the keyboard), then the number and confirm with [Return].

The design head stitch length is exclusively valid in the automatic programs. The maximum stitch length thus refers only to manual stitches and borer travel paths.

Set Markings

[Div] (on the number keypad of the keyboard) inserts a marking at the current position. These markings can be used subsequently to form, copy, edit or delete blocks.

Automatic programs

General remarks on automatic programs

The purpose of the automatic programs is to make your work easier. Areas can be filled with a certain type of stitch, and lines can be pricked out automatically. You can influence individual parameters, such as the stitch rhythm and pricking behavior.

Each automatic program is designed for a particular stitch filling and should be used accordingly. Satin stitch programs 1 to 5 are for filling satin stitch areas and behave accordingly at corners and when executing turns. Running stitch programs 10 to 13 are intended for filling large areas with running stitches. The running stitch areas should be such that the programs can divide up stitches according to the entered rhythm without permanently having to use special treatments (undivided stitches). If areas are filled exclusively by means of such special methods, an unsatisfactory result is obtained because the program has been incorrectly applied.

We cannot guarantee that effects that are achieved by setting parameters in a way other than that for which they were intended are wholly suitable for embroidering.

Calling an automatic program

Calling an automatic program takes you to an object in the design. A design is a sequence of objects that are linked by manual stitches. You can manipulate the stitches calculated by an automatic program in the editor. This excludes the object from further operations, such as calculation of the stitches. This restriction can be removed. ([Edit object stitches](#))

Various options are available for initiating an object. To restart the automatic program that was most recently used, press [F10] or [Return]. The name of this program appears in the assistant bar under *Program Info*. If you wish to start a different automatic program, press [F11] or [+] on the number keypad. The available programs appear (*Program selection*). Select the desired program from the list.

Once you have started an object, first enter the outlines or contours. Depending on the type of automatic program, further inputs may be necessary. The data that belong to an object are collectively known as the object reference data (*Reference data input*). Once all the entries have been made, the stitches are calculated automatically if you have selected *Automatic calculation after reference data input* in *Default settings*ID_Grundeinstellung Editor. If the outcome is unsatisfactory, you can call the object editor with [Delete] and then make changes.

Program selection

This is the on-screen dialog in which you select the desired automatic program. Various options are available for making the selection, the simplest of which is to click the relevant program. The most recently used parameter set is automatically assigned. If you know the number of the automatic program by heart, you can enter it directly. If you wish to use a specific parameter set, enter a dot and the number of the parameter set after the program number. The third option is available if the opened design already contains objects. These are shown as histograms in the *Input* box when you open it. Click <Left> on the desired program to preselect it. Press [Return] to confirm the selection.

Reference data input

The reference data input for an object is generally divided into the following sections:

- Recording the contours of the main figure
- Stitch direction markers
- Additional contours
- End point

Once the data have been entered, the stitches are calculated automatically and you are taken back to the part of the program where stitches can be entered manually. If the result is not to your liking, press [Delete] to call the object editor and make the necessary changes. If an error occurs during the calculation, the editor is called automatically. The cause of the error is described graphically and by plain text.

- Reference data Program 1-6 Satin stitch
- Reference data Program 10 Stepstitch Fill
- Reference data Program 11 Curved Stepstich Fill
- Reference data Program 12 Cross Stitch
- Reference data Program 20 Step-Lines
- Reference data Program 30 Cross Boll
- Reference data Program 31 Chain up objects
- Reference data Program 32 Objects on circle
- Reference data Program 33 Monograming

Contour



Contours are created by entering free-form curves. A contour can be entered by setting reference points in the "point mode". Alternatively, you can accept an existing contour either wholly or in parts. This form of input is referred to as the "line mode". The two modes can also be used in combination when entering a contour.

Contours are formed both to enter a drawing line and to create an object. The same operating principle applies in each case. Existing drawing lines can be used for punch contours, and existing punch contours can be used for drawing lines.



We start by describing how to enter a contour in the point mode. This is the mode that is available when "Contour" is called. Enter reference points with `<Left>`. Define corners with `<Left><Left>`.



When entering predominantly corners, you can switch to the corner mode with `[F4]` followed by `[2]`. In this mode `<Left>` creates a corner and `<Left><Left>` a reference point.



If you need orthogonal lines, switch to the straight-line mode with `[F4]` followed by `[3]`. Either a vertical or a horizontal line is created, depending on which is the longer element. Corners are entered with `<Left>`.

To place a reference point exactly on an existing line or the grid, you can approach the desired location with `[Shift] + <Left>`. If the program finds more than one line or the grid, select the desired line from the snap list. The reference point is placed at the snapped location. The grid can be approached only if *Enable snap radius* is selected in the grid set-up. **Grid**

Integrating existing lines

Pressing `[Strg] + <Left>` on an existing contour switches to the line mode and at the same time defines the start point of the part line. The end on the contour is also determined with `[Strg] + <Left>`. This takes you back to the point mode. If you wish to move from one line to another, the lines must have at least one intersection or contact point.

Completed part lines are marked green. In the line mode the current line is drawn red.

Pressing `[Return]` in the point mode creates a contour from the existing part lines and the new part of the contour up to the final entered point.

Pressing `[Return]` in the line mode creates a contour only with the part lines marked green. The current (red) line is disregarded.

Exception

If you initially selected an existing contour with `[Strg] + <Left>`, pressing `[Return]` accepts the whole line.

Pressing `[Esc]` after selecting at least one reference point or line with `[Strg] + <Left>` deletes the inputs made thus far. If you have not made any inputs, you are taken out of the contour definition operation.

Pressing `[Insert]` recreates the eliminated points provided that you have not entered any new

points since pressing [Delete].

Parallel mode



You can draw a parallel to an existing line or part line. First activate the parallel mode with [F9], then enter the start point of the parallel line as described above. Once you have confirmed the contour with [Return], you are asked to define the parallel spacing. You can enter it graphically or, with [F11], numerically. Pressing [Return] without [F11] accepts the default value.

Repositioning contour opening

With closed or continuous contours, the opening can be displaced. Once the contour has been confirmed, EPCwin offers this function if the program considers it useful. Pressing [Return] confirms the existing opening; a new position for the opening is defined with <Left>.

Reference data Program Satin stitch

Main contours

A satin stitch object consists of two main contours and stitch direction markers. Various options are available for recording the two main contours. First select the method you wish to use. Conclude the contour input operation with [Return]. Pressing [Esc] aborts the input routine.

Frame input



[F3] *Frame* enables you to create the two contours and the stitch direction markers at the same time. Pressing <Left> alternately enters a point for contour 1 and a point for contour 2. The first point for contour 1 is automatically the final manual stitch. The link between the two corresponding points is formed by a stitch direction marker.

If the point sequence is interchanged, the EPCwin system shifts the pair of points. Use <Left><Left> to integrate a corner in the contour. Pressing [Strg] + <Left> marks a corner that is to be approached. Pressing [Insert] recreates eliminated points provided that you have not entered any new points since pressing [Delete].

Segment



[F4] *Segment* cuts out the two contours from existing lines. First enter the initial stitch direction marker. Use <Left> to select the first point on a line. If there are several lines at this location, confirm the appropriate one in the snap list. A second <Left> defines the second point of the initial stitch direction marker. This point also has to be located on a line (it can be the same line). Pressing [Strg] + <Left> automatically selects the starting point of the line. The final stitch direction marker is defined with the third and fourth <Left>. Pressing [Strg] + <Left> automatically selects the end point of the line.

The procedure is subject to the following conditions:

- The first point of the initial and final stitch direction markers must be on the same line.
- The second point of the initial and final stitch direction markers must be on the same line.

Pressing [Insert] recreates eliminated points provided that you have not entered any new points

since pressing [Delete].

Contour



Pressing [F5] *Contour* enables you to enter the two main contours successively using the conventional line input method offered by the EPCwin system; see [Contour](#)

Circle



Pressing [F7] *Circle* enables you to create a circle. Use <Left> to enter the three points that define the circle.

If the third point is <Left><Left>, an arc is obtained. This also ends the circle input. To obtain a full circle, press [Return] after entering the third point. This concludes the circle input.

Enter the stitch direction and width of the circular ring with <Left>. If you wish the stitch direction marker to pass through the center of the circle, enter [Strg] + <Left> as the width. The circumferential direction of the filling corresponds to the direction defined by the three entered points.

Center line



Pressing [F8] *Center line* enables you to create a center line with two parallels at a distance you can specify.

This input form is based on the frame input and contour definition procedures with which you are already familiar. Enter the center line with the contour function. The frame input allows manual corners and non-parallel sections to be defined in the satin stitch object. Press [Return] to switch between the two input forms. If [Return] is pressed before a point has been entered in the current section, the input is concluded. Pressing <Left> initiates the border width input; pressing <Left> a second time concludes the input. Pressing [F11] enables you to make a numerical input and [Return] accepts the default value.

On concluding the input the parallels are calculated and the stitch direction markers defined at a right angle to the center line. Outside corners are detected and approached automatically.



Execution of the corners is controlled with [F10] *Miter* switch. If the *Miter* mode is active, the corners are automatically executed as miter corners. With the *Corner* mode selected, the corners are automatically executed as normal corners

Stitch direction input



Once you have entered the two contours, you can add the stitch directions (apart from with 'Frame'). Existing design stitch direction markers are automatically taken over. New stitch direction markers are defined by entering two points with <Left>.

To define a corner you wish to approach, enter <Left> <Left>. If the contour contains a corner in the vicinity of this point, the stitch direction marker is automatically positioned in this corner.

To define a miter corner, enter [Strg] + <Left>. The parameters for a miter corner are set with [F11] "Parameters" ([Stitch direction parameters](#)). The stitch direction marker for a miter corner is drawn as a broken line.

Input of the stitch direction markers is concluded with [Return]. The stitch direction markers are automatically cut off at the edge of the contour.

Information

The function for cutting off the stitch direction markers does not work unless the center of the stitch direction marker is located between the two contours.

Dividing line input



This input is required only with program 4. A dividing line has to be entered with program 5 only if the "dividing line" parameter is ticked in the parameter set. Dividing lines are entered with **Contour**.

End point input

The end point defines where the calculation is to stop; in other words, this point corresponds to the last calculated stitch.

Set the end point with <Left>; the stitches are automatically calculated straight away.

Entering the end point determines the direction of the filling. The direction is always such that the majority of the area is filled towards the corner point.

The end point can be defined in three different areas:

End point located at end of main figure

The reticle or cross-hair pointer changes to green when you enter the snap radius for the end of contour. Press <Left> to set the end point exactly on this contour point. The end point can also be defined after the final stitch direction marker in the direction of embroidery. No running stitch is executed.

End point located at start of main figure

The reticle or cross-hair pointer changes to green when you enter the snap radius for the start of contour. Press <Left> to set the end point exactly on this contour point. The end point can also be defined before the initial stitch direction marker in the direction of embroidery. A running stitch is executed. The running side is defined in the parameter set. The overlap stitches are not executed.

End point lies between initial and final stitch directions

In this case, the object is divided into two parts. A running stitch is executed between the two parts in compliance with the parameter set (PS). The running side is determined by the parameter set. The number of overlap stitches is incremented by 1 if the final stitch before the running stitch ends on the wrong side.

Pressing [Return] positions the end point at the end of the second contour.

Reference data Program Stepstitch Fill

Contour

The outline or outer contour is entered with **Contour**.

Caution

**The outline is completed automatically. You should not complete the contour yourself.
Avoid loops when entering the contour.**

Stitch direction



Enter two points with <Left> to define the stitch direction. Press [F11] to enter the angle as a numerical value. Press [Return] to select the angle of the last running stitch object.

With the last two input forms, a stitch marker 2 cm long is drawn at the location marked by the cursor cross-hairs.

- 0 degrees: Stitch direction from bottom to top
- 90 degrees: Stitch direction from left to right
- 180 degrees: Stitch direction from top to bottom
- 270 degrees: Stitch direction from right to left

The direction of the stitch direction marker is important for the position of the stencils.

Horizontal stitch direction



Press [F9] to enter a horizontal stitch direction marker. A stitch marker 2 cm long is drawn at the location marked by the cursor cross-hairs.

Vertical stitch direction



Press [F10] to enter a vertical stitch direction marker. A stitch marker 2 cm long is drawn at the location marked by the cursor cross-hairs.

Additional contours

You can add holes, satin stitch holes and dividing lines in any order. Press the relevant softkey and enter the **Contour** as usual.

Holes



Press [F2] to switch to the input routine for holes. Holes interrupt the filling of the internal surface.

Satin stitch holes



Press [F3] to switch to the input routine for satin stitch holes. Satin stitch holes interrupt the step rhythm.

Dividing line



Press [F4] to switch to the input routine for dividing lines. Dividing lines necessitate the insertion of a stitch at the point of intersection with a running stitch line. Accentuated points allow points on a dividing line to be emphasized. A stitch is always inserted at this point. To define an accentuated point in the editor, click the reference point and transform it into an accentuated point with [F5].

Caution
Holes and satin stitch holes are completed automatically. You should not complete the contour yourself.
Avoid loops when entering the contour.
The contours must not intersect and must not be located outside the outline or intersect with the latter.
Dividing lines are not bound by these restrictions.

Program 13 "Objects in areas" does not allow satin stitch holes or dividing lines.

End point

The end point defines where the calculation is to stop; that is to say, this point corresponds to the last calculated stitch.

Set the end point according to your individual choice with <Left> or press [Return] to place the end point exactly at the start point of the object, namely the final manual stitch before the object. The stitches are automatically calculated straight away.

Block - program 13 only

Enter the block number (**Block**) whose data you wish to spread in the contour. You can only spread blocks that have already been created.

Reference data Program Curved Stepstich Fill

Contour

Enter the main figure with the frame input; see [Reference data Program Satin Stitch](#)

Caps

The caps can be entered in any order with the aid of [Contour](#).

The cap end point located nearest to the last manual stitch automatically becomes the start point for the calculation. The calculation ends at the other end of the cap.

Caution
The first and last points of a cap must be located close to a support point of the main figure.

The first and last points of a cap must not be located on the same outer edge.

The cap must be entirely located inside the main figure.

Cap parts that protrude from the main figure are ignored.

The caps must not intersect.

Reference data Program Cross Stitch

The reference data for cross stitch observe the sequence:

- Grid
- Cross stitch direction
- Cross input
- End point

Grid

First enter two points with <Left> to define the grid cell size and the angle of the grid. Alternatively, press [F11] to obtain the on-screen dialog for entering the dimensions directly **Cross stitch parameters**; this dialog also appears if you elect to enter the two points first.

Cross stitch direction

Once you have entered the size and position of the crosses, you can move the grid; it tracks the movement of the mouse. On reaching the desired location, fix the position of the grid with <Left>. If the grid was not moved, the left bottom corner of a grid cell is aligned with the final manual stitch.

If you use the cross stitch program repeatedly, you can take over the grid created with the previous cross stitch program session.

Cross input

The following options are available when entering crosses:

- <Left> inside a grid cell to enter a cross
- [Shift] + <Left> inside a grid cell to enter a zigzag
- [Backspace] or [Delete] deletes the previous cross
- [Insert] recreates the most recently deleted cross
- [Return] closes the cross input routine

The last manual stitch is taken to the first cross. If the distance is too great, a stitch is inserted.

You do not have to define the exact center point of the cross; a point inside the grid is sufficient. A series of associated crosses on a straight line or diagonal of the grid do not have to be entered individually; simply click the first and last center points.

If you enter a grid cell that cannot be obviously linked with the previously defined grid cell, the entry is ignored and a brief audible warning signal is issued.

In some cross stitch designs, a single path has to be input twice. In this case, enter the grid cells (up to the penultimate one) with [Shift] + <Left> and with <Left> on the return run. The cells entered with [Shift] + <Left> are executed with individual zigzag stitches and those repeated with <Left> with cross stitches. The cross stitch program recognizes that a part of these crosses has already been embroidered and thus embroiders only the remaining part of the cross and the repetition. This always produces an optimum number of stitches.

End point

When you conclude the cross input routine, all four possible end points are marked on the final cross with yellow points. Click one of these with <Left>. Pressing [Return] accepts the left bottom corner of the final cross as the default end point.

Reference data Program Step-Lines

Contour

Enter the main line with **Contour**.

Auxiliary line

Enter the auxiliary lines with **Contour** as well.

The connecting point of an auxiliary line is searched automatically and marked with a green point.

Parameter set



After entering a (main or auxiliary line), press [F8] PS to input the desired parameter set. (Parameter set).

End point

The end point is automatically determined by the number of runs and is located either at the end or the start of the main line.

Reference data Program Cross Boll

Circle

The last manual stitch is automatically the first point of the circle. Enter the second and third points with <Left>.

End point

The end point and start point are always identical with cross bolls.

Reference data Program Chain up objects

Dividing line

Enter the dividing line with Contour.

Block

Enter the number of the block (Block) whose data you wish to spread on the line. Only blocks that have already been generated can be spread.

Reference data Program Objects on circle

Circle

The last manual stitch automatically becomes the first point on the circle. Enter the second and third points on the circle with <Left>.

Block

Enter the number of the block (Block) whose data you wish to spread on the line. Only blocks that have already been generated can be spread.

Reference data Program Monograming

Dividing line

Enter the dividing line with Contour.

Stitch direction parameters

This on-screen dialog enables you to set the parameters of a stitch direction marker within a satin

stitch object. Entries that are made apply to the current and all the following stitch direction markers. Changes made in the editor also apply from the selected stitch direction marker to the end of the object. If you wish to make several changes, it is important to note the direction of the object otherwise modifications that have already been may be overwritten by subsequent ones.

General parameters

Stitch distance



You can set this parameter only if the stitch distance ramp is deselected, that is to say set to 0, in the parameter set.

Setting the stitch distance ensures compliance with the new distance at this stitch direction marker. The ongoing distance adjustment takes effect from the preceding stitch direction marker.

Stitch shortening



Enter the new value for stitch shortening here.

Miter corner

Overlap



The overlap value range is 0 to 127; it defines the elongation of the stitches towards the corner. The length of stitch for the return path is one-third of the overlap length.

Round

The tip stitch of a miter corner is shortened to form a "round" corner with the two adjacent stitches. This action prevents the tip stitch being severed when the embroidery is cut out.

All corners of the object

The modifications are to apply not only to the selected miter corner, but to all the miter corners of the object.

Cross stitch grid parameters

This on-screen dialog enables you to enter the cross stitch settings directly.

You can enter the grid cell size, number of crosses and grid angle in the relevant boxes.

Move grid

This button determines whether the grid is to be moved once the dialog is closed.

Cancel

This button aborts the dialog; the settings that applied before the dialog was called are retained.

OK

This button closes the dialog; the new settings for the grid cell size, number of crosses and grid angle

are accepted.

Point/Corner/Straight Line

The editor enables you to modify existing design and punch data. You can edit, insert or delete manual stitches, stitches generated by automatic programs (object stitches), special functions, the maximum stitch length, automatic jump stitch, markers, drawing lines and drawing points. You can also edit the parameters and reference data of objects.

If you select only a single element (such as one drawing point or one drawing line), you can execute a **Single action** `ID_Einzelaktion` that applies only to the selected element. In all other cases, an **Edit box** appears.

Items can be selected only if they are set to be visible with the view tool.

The standard screen display is as follows during editing:

Current image section

The current image section contains the reference and stitch data for the design you are currently editing. If so wished, you can also display the relevant drawing and/or the scanned image.

For further information, see **General functions**.

The window can be moved (scrolled) by moving the cursor (cross-hair pointer) to the edge of the display with the puck.

Overview window

The overview window contains the complete design. The current image section is outlined in the overview window.

Assistant bar

The bar indicates the enlargement factor (zoom), number of stitches contained in the design, current automatic program, status of the special functions and, at the bottom right, the current stitch list.

Display of softkey functions

The relevant assignment of the softkeys `[F1]` to `[F12]` is indicated at the bottom left of the screen.

Softkey functions



- `[F3]` defines the **Type of selection**



- `[F4]` switches between the gray and color display



- `[F6]` selects and deselects filter functionality



- `[F7]` sets the filter functions



- `[F8]` switches between the large and small depiction of the stitch list



- [F12] select special functions for a stitch

Switch to block list

Pressing [Alt] or [F] activates and deactivates the block list. If the block list is not switched on, pressing [Alt] or [F] switches it on and activates it at the same time.

When the block list is active, the cursor takes the form of an arrow; only elements in the block list can be selected. When the block list is inactive, the cursor takes the form of a cross-hair pointer; only elements in the working window can be selected.

Block list

Data selection

You can select data in several different ways:

- By clicking with the mouse ([Single selection](#))
- [Multiple selection with rectangle](#)
- [Multiple selection with polygon](#)
- [Continuous selection](#)
- [Select in block list](#)

Type of selection

There are several different ways of selecting data:

Single selection



You can select one or several design elements (design, contour, stitches). See [Single selection](#).

Block filter active



When you activate the block filter, with "Single selection" a stitch area determined by the setting of the [Block filter](#) is automatically selected.

See also [Continuous selection](#).

Rectangle



With this type of selection you select one or several design elements located inside a rectangle. See [Multiple selection with rectangle](#).

Surround



Here you select design elements by tracing around an area (forming a polygon). See [Multiple selection with polygon](#).

Total design



Selects the entire design. A dialog enables you to determine which design constituents (design lines, punch data, remarks and help lines) are to be taken into account.

Also single points

This option applies to *Rectangle* and *Surround*. If it is activated, you can also select points on a line with rectangle and polygon selection.

If the option is deactivated, in the case of lines, you can only select lines that do not extend beyond the area.

Request at deselection

If you select design elements by way of a single selection with the Control key pressed down and then select an individual element without the Control key pressed, the previously selected elements are deselected.

If you activate this option, you are asked to confirm that you wish to deselect the previously selected elements. The setting in *Selection / Default setting* determines the minimum number of selected elements that triggers this inquiry.

Block management



This is a tool for managing the saved blocks, including functions for deleting as well as creating and renaming directories. *Block management*.

Load block



Here you can integrate a saved block at the current position in the design. *Load block*.

Short cut

This option allows you to enter numbers instead of pressing buttons.

Single selection

Single selection enables you to select specific individual elements of the design.

Pressing <Left> selects an individual element. If other elements have already been selected, an on-screen dialog, *Single-click selection*, allows you to decide whether to retain the marked elements. If you decide against retention, only the currently marked element is accepted.

Use [Strg] + <Left> to select a succession of individual elements and thus form a selected lot. You confirm the selection with [Return] or by clicking the right mouse button.

If you reselect a marked element with [Strg] + <Left>, it is eliminated from the current selected lot.

Pressing [Shift] + <Left> on a stitch eliminates all previously selected elements from the selected lot. The new element (a stitch) then forms the limit (the upper or lower limit) of a stitch area. Executing the same action on another stitch concludes the area definition routine. You can edit the element lot, that is to say eliminate stitches or add further individual elements, with [Strg] + <Left>. You confirm the selection with [Return] or by clicking the right mouse button.

The same applies to monogram characters.

The selection is governed by the (filter) settings defined in the on-screen dialog *Type of selection*. This

dialog allows you to switch between the different types of selection with **[F3]**; you can choose to select whole objects, stitch areas between two special functions or two markers, or individual elements, depending on the setting of the block filter.

Special function:

The following applies to overlapping stitch areas when forming lots with the Control key pressed down: If the same area is reselected, it is eliminated from the lot of selected elements.

If a selected area is entirely contained within another area, the overlap lot is eliminated.

If a selected area is not entirely contained within another area, but the other area forms overlap lots with other stitch areas, all the areas are amalgamated.

Cursor keys:

The cursor keys enable you to navigate through the design stitch by stitch. For further information, see [Continuous selection](#).

In this case a stitch is always preselected. Pressing **[Return]** enables you to edit the stitch. You can also manipulate the stitch directly as indicated below.

For manual stitches:

[Insert]	Change to insert mode
[Delete]	Delete stitch
[F11]	Switch between jump stitch and stitch point
[F12]	Edit / insert special function
[Div]	Edit / insert marker
[*]	Edit / insert change in maximum stitch length
[L]	Load block
[Ctrl] + [V]	Load block 1.1

Edit manual stitches

For object stitches:
see manual stitches.

In addition, pressing **[0]** on the number keypad takes you to the object editor, where the object's reference data can be edited.

Edit object stitches

Single-click selection

Here you can decide whether to retain the elements that are already marked. If you respond with **Yes**, the currently selected element is not accepted. If you respond with **No**, only the currently selected element is accepted; the data marking operation is terminated. **Cancel** has the same effect as **No**.

Pressing **[F3]** obtains the dialog **Type of selection**, which allows you to switch between the different means of selection.

Multiple selection with rectangle

A selected lot is formed by tracing a rectangle. Press **<Left>** twice to create a rectangle; the two points represent diagonally opposite corners of the rectangle.

All the design elements contained within the rectangle form a new selected lot. Depending on the setting, the selected lot contains either only the objects and elements that are fully enclosed by the rectangle, or only parts of the individual elements (such as points of a drawing line rather than the entire line).

Pressing **[F3]** obtains the dialog **Type of selection**, which allows you to switch between the different

means of selection.

Multiple selection with polygon

A selected lot is formed by tracing a polygon around the area you wish to select. Create the corner points of the polygon with <Left>. Mark the end point of the polygon with [Return].

For further information, see [Multiple selection with rectangle](#).

Pressing [F3] obtains the dialog [Type of selection](#), which allows you to switch between the different means of selection.

Continuous selection

You can navigate to and fro through the design stitch by stitch with the cursor keys (depending on the setting, arrow up and down or arrow left and right). The current stitch is marked yellow. Pressing [Return] confirms that this individual stitch is to be selected. The navigation is governed by the setting of the [Block filter](#) made in the dialog obtained with [F3].

The following rules apply:

Marking with [Single selection block filter](#) not active: The filter setting ([F6], [F7]) applies.

Marking with [Single selection block filter](#) active: The filter setting ([F6], [F7]) does not apply. The setting of the [Block filter](#) applies.

If a current stitch is not yet selected, moving forwards marks the first stitch and moving backwards marks the final stitch.

When navigating stitch by stitch, only one stitch is marked at a time.

Navigation takes place in three increments: small, medium and large. Set the increments under [Default settings](#).

If the left/right pair of cursor keys is set for navigation in small increments, the up/down pair of cursor keys controls navigation in medium increments. Holding down the Control key while operating the pair of cursor keys for medium increments enables you to navigate in large increments. Holding down the Control key while operating the pair of cursor keys for small increments enables you to navigate only along the object limits.

You can form stitch areas by holding down the Shift key at the same time. Depending on the direction of navigation, the area gets larger or smaller as you proceed. If only a single stitch is marked (the starting stitch for formation of a stitch area), the stitch area is enlarged towards the end of the design if you navigate forwards, or it is made smaller in the direction of the start of the design if you navigate backwards.

If a stitch area has already been formed, you can decide with [F9] whether the starting stitch is to be at the start or end of the stitch area. If the starting stitch is the first stitch of the stitch area, you enlarge the stitch area towards the start of the design and reduce it in the direction of the end of the design. If the starting stitch is the final stitch of the stitch area, the same rule applies, but in reverse.

If reducing a stitch area gives rise to only a single marked stitch, the rules for navigating stitch by stitch apply.

If several stitch areas exist (an area can consist of just a single stitch), [F9] switches only between the starting stitch of the first stitch area and the end stitch of the final stitch area.

Select in block list

"Select in block list" is an option that enables you to select specific individual blocks of the design.

Press <Left> to select a single block. Press [Strg] + <Left> to select a succession of individual blocks, thus forming a selected lot. Confirm the selection with [Return] or <Right>.

Selecting a marked block again with [Strg] + <Left> has the effect of eliminating it from the current selected lot.

Pressing [Shift] + <Left> on a block eliminates all the previously selected blocks from the selected lot. The new block constitutes the (upper or lower) limit of an embroidery area. Executing the same operation on another block concludes the area formation exercise. Use [Strg] + <Left> to modify the selected lot of elements; that is to say, to eliminate or add single blocks. Confirm the selection with [Return] or <Right>.

Further information is contained under [Block list](#).

Block filter

Block filter is a function used to determine block limits in the design. Dividing the design into blocks facilitates the selection of embroidery areas. The blocks created in this way are displayed in the [Block list](#). The block filter settings apply both in the block list and with [Single selection](#) with block filter active.

[Block filter multi-head](#)

[Block filter schiffli](#)

Block filter multi-head

Block filter is a function used to determine block limits in the design. Dividing the design into blocks facilitates the selection of embroidery areas. The blocks created in this way are displayed in the [Block list](#). The block filter settings apply both in the block list and with [Single selection](#) with block filter active.

Filter criteria

The filter criteria are divided into two sets, namely group 1 and 2.

Group 1

A block is divided into two parts because the thread between the final stitch of the first block and the first stitch of the second block is trimmed. The path between the blocks is not embroidered.

Among these filter criteria are:

Needle change:



Thread trimming:



Head shutdown:



From stitch length:



All stitches that are longer than the set value give rise to a new block.

Group 2

A block is divided into two parts because of a particular event. The final stitch of one block coincides with the first stitch of the following block.

Among these filter criteria are:

Stop:



Chain/moss/coiling:



Cord:



Loop:



Marker:



The block limit is defined by setting markers manually. You can define and delete this type of marker while punching and in the editor.

Object:



The block limit is defined by an object; the manual stitches between two objects form a separate block.

Rules of block formation

If two filter criteria, one from each of group 1 and group 2, coincide at a block limit, the block limits are formed according to the rules of group 1.

Exception: If a *Stop* special function occurs between two blocks separated by a group 1 criterion, the block limit is formed at the stitch belonging to the stop.

Block filter schiffli

Block filter is a function used to determine block limits in the design. Dividing the design into blocks facilitates the selection of embroidery areas. The blocks created in this way are displayed in the **Block list**. The block filter settings apply both in the block list and with **Single selection** with block filter active.

Filter criteria

The filter criteria are divided into two sets, namely group 1 and 2.

Group 1

A block is divided into two parts because the thread between the final stitch of the first block and the first stitch of the second block is trimmed. The path between the blocks is not embroidered.

Among these filter criteria are:

Needle on/off:



Repeat and color change:



Thread trimming:



Group 2

A block is divided into two parts because of a particular event. The final stitch of one block coincides with the first stitch of the following block.

Among these filter criteria are:

Stop:



Text:



Marker:



The block limit is defined by setting markers manually. You can define and delete this type of marker while punching and in the editor.

Object:



The block limit is defined by an object; the manual stitches between two objects form a separate block.

Rules of block formation

If two filter criteria, one from each of group 1 and group 2, coincide at a block limit, the block limits are formed according to the rules of group 1.

Exception: If a *Stop* special function occurs between two blocks separated by a group 1 criterion, the block limit is formed at the stitch belonging to the stop.

Tag stitches

The following sequence constitutes a tag stitch:

- Jump thread
- Sequence of stitches
- Jump thread

To allow a stitch sequence to be interpreted as a tag stitch, the minimum path of the jump threads and the maximum number of stitches in between have to be entered in the relevant value input fields.

These values are evaluated when the tag stitches option is activated.

Single action

Once you have selected a single element, you can perform various actions with it depending on the type of element:

- Edit manual stitches
- Edit special functions
- Edit maximum stitch length
- Edit marker
- Edit object stitches
- Edit objects
- Edit contour line
- Edit contour point
- Edit stitch direction marker
- Edit end point
- Edit cross point
- Edit drawing line
- Edit drawing line point
- Edit drawing object
- Edit drawing object contour
- Edit drawing object contour point

Edit manual stitches

Move

Move the stitch to the new position and confirm with <Left>.

Delete

To delete the stitch, press [Delete].

Insert

Press [Insert] to switch to the insert mode. Punch the missing stitch sequence. You can use all the functions available for **Manual punching** except editor and design. To exit the insert mode, press [Esc].

Displacement



Press [F4]. A dialog appears on the screen. The current path traced by the stitch is indicated in the box labeled *New displacement*. Enter the desired path. The following stitches to the end of the design are modified accordingly. The dialog also presents a box labeled *Taking back*; if you wish to reinstate the former displacement, simply proceed as though you wished to enter a new value and then select *Taking back*. It is important that you proceed in the direction of the design. If this function is executed at several locations in the design, the displacements are added together.

Sequin



Press [F6] to apply a sequin or to delete an existing sequin. Make certain that the sequin function is

already selected for the stitch concerned.

Jump stitch/Stitch



Press [F11] to transform a stitch point into a jump stitch and vice versa.

Edit special functions



Press [F12] to **Edit a special function** that already applies to the stitch or to insert a new special function.

Edit maximum stitch length

Press [*] to **Edit a change in maximum stitch length** that already applies to the stitch or to insert a new change in maximum stitch length.

Edit marker

Press [Div] to **Edit a marker** that already applies to the stitch or to insert a new marker.

Edit special function

Delete

To delete a special function, press [Delete]. If several special functions apply to the stitch in question, an on-screen dialog opens in which the relevant special functions are marked; click the special function you wish to delete.

Insert

Press :Einfg: to insert a new special function. (**Special function**)

Exchange



Press [F4] to exchange a special function for a different one. If several special functions apply to the stitch in question, an on-screen dialog opens in which the relevant special functions are marked; click the special function you wish to exchange and then the one you wish to insert in its place. (**Special function**)

Change



Press [F5] to change the status of a special function. This option is available only for needle change, head selection and head jump. If several special functions whose status can be changed apply to the stitch in question, an on-screen dialog opens in which the relevant special functions are marked; click the special function you wish to change. Select the new needle or head selection or enter the new head jump.

Edit maximum stitch length

Delete

Press [Delete] to delete a change in maximum stitch length.

Insert

Press [Insert] to insert a new change in maximum stitch length. (Maximum stitch length)

Change



Press [F3] to edit the change in maximum stitch length. Enter the new value.

Edit marker

Delete

Press [Delete] to delete the block marker.

Insert

Press [Insert] to insert a block marker. (Set markings)

Edit object stitches

As soon as you edit an object stitch, the object is barred from calculation (the start point is marked yellow). Click on the object if you wish to enable it again. The object is enabled once you confirm the inquiry that appears. Calculate the object. Note that this operation deletes changes you made to the object stitches.

Move

Move the stitch to the new position and confirm with <Left>.

Delete

To delete the stitch, press [Delete].

Insert

Press [Insert] to switch to the insert mode. Punch the missing stitch sequence. You can use all the functions available for Manual punching except editor and design. To exit the insert mode, press [Esc].

If you have punched an object in the new stitch sequence, the object into which the sequence is to be integrated is converted to manual stitches.

Sequin



Press [F6] to apply a sequin or to delete an existing sequin. Make certain that the sequin function is already selected for the stitch concerned.

Jump stitch/Stitch



Press [\[F11\]](#) to transform a stitch point into a jump stitch and vice versa.

Edit special functions



Press [\[F12\]](#) to [Edit a special function](#) that already applies to the stitch or to insert a new special function.

Switch to object editor

Pressing [\[0\]](#) takes you to the object editor, where you can edit the object's reference data.

Note

With object stitches you cannot insert markers or changes to the maximum stitch length.

Edit objects

Delete object

Press [\[Delete\]](#); the object is deleted once you confirm the safety inquiry.

Insert in object



Pressing [\[F6\]](#) or [\[Insert\]](#) enables you to insert missing parts in an object. The elements that you are able to add depends on the type of automatic program. The options are listed below.

Satin stitch object:

Stitch direction markers and dividing lines [Reference data Program Satin stitch](#)

Step stitch object:

Holes, satin stitch holes and dividing lines [Reference data Program Stepstitch](#)

Step-line object:

Auxiliary lines [Reference data Program Step-Lines](#)

Change distance



Press [\[F7\]](#) to change the stitch distance for a satin stitch or step stitch object. The setting applies to the entire object.

Edit parameter set



[\[F8\]](#) enables you to edit the [Parameter set](#) for the object.

The EPC system examines whether the edited parameter set is used in another object as well. With program 20 (step-lines), the examination also covers the auxiliary lines in the same object. If the change is to apply only to the present object, press *No* and select an unassigned design parameter set (DPS). If you answer *Yes*, the changes also apply to all other objects.

Note that the other objects are not automatically calculated with the edited parameter set. You have to initiate a calculation in [Global Edit](#)

Information

Programs 33 (monogram) and 34 (TrueType monogram) do not have any parameter sets. Each object has individual parameters.

Exchange parameter set



Press [F8]. Click the parameter set you wish to insert. If you select a system parameter set, it is copied to a design parameter set with the same number provided that a set with that number does not already exist. If the number has already been assigned to a different design parameter set, the system issues an unassigned number.

Note

Within the satin stitch family (programs 1 - 6) you can change the satin stitch type (e.g. 1 -> 2) by pressing the relevant program number in the parameter set. You then have to select a parameter set for the new automatic program.

Exchange block



Press [F7] to exchange a chain block for programs 13, 31 and 32. You can specify the new block in the block manager.

Convert object



Press [F3] to convert an object.

You can convert a satin stitch object with the contour type center line or circle to a normal object with two outer contours or outlines. You can then edit these two contours as you wish.

You can convert chain-up objects (programs 13, 31 and 32) to sub-blocks that can also be edited individually. On conversion, the sub-blocks have not yet been calculated. Initiate this operation with the relevant function of [Global Edit](#).

All objects can be converted to manual stitches; the reference data are eliminated.

Edit contour

Move

Move the contour to the new position and confirm with <Left>.

Delete

To delete a contour, press [Delete]. You can only delete holes, dividing lines and satin stitch holes in step stitch objects and auxiliary lines in step-line objects.

Insert

Press [*Insert*] to insert a contour point. Move the new contour point to the desired position and confirm with <Left>.

Exchange



Press [*F4*] to exchange this contour for a new one. Enter the new contour with *Contour*.

Change



Press [*F5*] to swap the two outer contours of a satin stitch object. With some stitch rhythms, this gives rise to a different distribution.

Reverse



In the case of closed figures, pressing [*F6*] reverses the direction. This action also changes the direction in which the object is filled.

Stitch distance



Press [*F7*] to change the stitch distance for a satin stitch or step stitch object. The setting applies to the entire object.

Parameter set



[*F8*] enables you to edit the *Parameter set* for the object.

Width



Press [*F11*] to edit the border width of a satin stitch object with a center line, then enter the new value.

Edit contour point

Move

Move the contour point to the new position and confirm with <Left>. Pressing [*Shift*] at the same time draws the contour point towards an existing contour.

Delete

Press [*Delete*] to delete the contour point. Some contour points cannot be deleted. If a contour consists of only two points, for example, one point cannot be deleted or else the contour would be

incomplete. A contour must consist of at least two points.

Point



Press [F3] to transform a corner into a contour point.

Corner



Press [F3] to transform a contour point into a corner.

Accentuation of the point



Press [F5] to transform a contour point into an accentuated point or vice versa. This function is available only with dividing lines in program 10 and with stencils. A step stitch is always executed at the accentuated point. This allows you to emphasize a tight curve in the dividing line.

Stitch distance



Press [F7] to change the stitch distance for a satin stitch or step stitch object. The setting applies to the entire object.

Parameter set



[F8] enables you to edit the **Parameter set** for the object.

Edit stitch direction marker

A distinction is made between the stitch direction markers for the satin and step stitch families.

A satin stitch object must contain at least two stitch direction markers (the initial and final markers). The parameters of the other stitch direction markers influence the execution of the satin stitch.

A step stitch object contains only one stitch direction marker, which does not have any additional parameters.

Move

Move the stitch direction marker to the new position and confirm with <Left>.

Information

If you move the initial or final stitch direction marker, you automatically move the start and end points of the contour as well.

If you move the stitch direction point of a corner that is to be approached, you also move the corner point in the outer contour at the same time.

Delete

Press [Delete] to delete a stitch direction marker. Only the "normal" stitch direction markers of a

satin stitch object can be deleted. The initial and final stitch direction markers of a satin stitch object and the stitch direction marker of a step stitch object cannot be deleted.

Corner



If you press [F4] *Corner*, the corner is approached or, if the point was already marked as a corner, the marking is removed. Corners are marked green and supported only in satin stitch objects.

Miter



Pressing [F3] *Miter* causes the corner to be executed as a miter corner. The parameters of the miter corner are defined in the on-screen dialog *Stitch direction parameters*. The corners are marked violet and supported only in satin stitch objects..

Stitch direction parameters



Press [F11] to edit the *Stitch direction parameters*.

Edit end point

Move the end point to the new desired position and confirm with <Left>.

Input end point satin stitch

Input end point step stitch

Input end point cross stitch

Edit cross point

Move

Move the cross point into the desired grid field and confirm with <Left>.

Caution

The system verifies that the changes you made were permissible before carrying out a calculation. If they were not, the illegal cross path is marked in green.

Delete

Press [Delete] to delete the current cross point.

Insert

Press [F6] or [Insert]. This selects the insert mode at the current position. Enter the missing section of the cross path in the usual way. (*Reference data Program Cross stitch*)

Deselect the insert mode with [Return].

Cross



Pressing [F4] transforms the point into a cross point.

ZigZag



Pressing [F4] transforms the point into a zigzag point.

Edit drawing line

Move

Move the drawing line to the new position and confirm with <Left>.

Delete

Press [Delete] to delete the drawing line.

Copy



Press [F2] to copy the drawing line. Move the new drawing line to the new position and confirm with <Left>.

Edit-Box



Press [F3] to call the box function for this drawing line. **Edit box**

Cut off with present drawing line



Press [F6] to use the present drawing line as a cutout or cutoff contour. The drawing lines that intersect with this drawing line are cut off at the intersection.

Cut



Press [F7] to cut the drawing line at the selected place.

Join



If the start or the end of a line is situated in the vicinity of the start or end of another line, the two lines are joined to form a single line.

Parallels



Press [F9] to create a line parallel to the current drawing line. Enter the direction and the parallel spacing and confirm with <Left>. Alternatively, you can enter the spacing as a numerical value. Determine the direction by moving the cursor to the desired side of the contour and pressing [F11] to make the input. Enter the spacing and number of repetitions. *Automatic corners* calculates the corners automatically.

Divide



Pressing [F10] enables you to divide the drawing line into equal parts; enter the number of parts. The sections of the line are marked by short lines.

Line color



Press [F12] to change the color of the drawing line.

Edit drawing line point

Move

Move the drawing line point to the new position and confirm with <Left>.

Delete

Press [Delete] to delete the drawing line point. If the resulting drawing line consists of only two points, the entire line is deleted.

Corner



Press [F3] to transform a reference point into a corner.

Point



Press [F3] to transform a corner into a reference point.

Cut



Press [F7] to cut the drawing line at the selected place.

Join



If the start or the end of a line is situated in the vicinity of the start or end of another line, the two lines

are joined to form a single line.

Parallels



Press [F9] to create a line parallel to the current drawing line. Enter the direction and the parallel spacing and confirm with <Left>. Alternatively, you can enter the spacing as a numerical value. Determine the direction by moving the cursor to the desired side of the contour and pressing [F11] to make the input. Enter the spacing and number of repetitions. *Automatic corners* calculates the corners automatically.

Line color



Press [F12] to change the color of the drawing line.

Edit drawing object

Delete object

Press [Delete]; the object is deleted once you confirm the safety inquiry.

Change distance



Press [F7] to edit the stitch distance.

Edit parameter set



[F8] enables you to edit the **Parameter set** for the object.

The EPC system examines whether the edited parameter set is used in another object as well. With step-lines (running stitch lines), the examination also covers the auxiliary lines in the same object. If the change is to apply only to the present object, press *No* and select an unassigned design parameter set (DPS). If you answer *Yes*, the changes also apply to all other objects.

Note that the other objects are not automatically calculated with the edited parameter set. You have to initiate a calculation in **Global Edit**

Exchange parameter set



Press [F8]. Click the parameter set you wish to insert. If you select a system parameter set, it is copied to a design parameter set with the same number provided that a set with that number does not already exist. If the number has already been assigned to a different design parameter set, the system issues an unassigned number.

Edit object parameters



Press [F11] to edit the object parameters.

Convert object



Press [F3] to convert an object.

All objects can be converted to manual drawing lines; the reference data are eliminated.

Edit drawing object contour

Exchange



Press [F4] to exchange this contour for a new one. Enter the new contour with **Contour**.

Line color



Press [F12] to change the color of the drawing line.

Edit drawing object contour point

Move

Move the contour point to the new position and confirm with <Left>. Pressing [Shift] at the same time draws the contour point towards an existing contour.

Delete

Press [Delete] to delete the contour point. Some contour points cannot be deleted. If a contour consists of only two points, for example, one point cannot be deleted or else the contour would be incomplete. A contour must consist of at least two points.

Corner



Press [F3] to transform a reference point into a corner.

Point



Press [F3] to transform a corner into a reference point.

Bohrstäffel: open corner



Press [F3] and [F4] to obtain an open corner.

Bohrstffel: corner with leg



Press [F4] to obtain a corner with a leg.

Edit-Box

General explanation

The edit box has two modes of operation. In mode 1 you can move, extend/compress or change the proportional size of the box. In mode 2 you can move, rotate and make the box slant. Clicking on the box or pressing [F5] changes its mode. The cursor and the box markers indicate the current box mode. In mode 1 the corners of the box are depicted with square markers. In mode 2 they are depicted with red dots, as is the point of rotation.

Move

Clicking <Left> in the edit box enables you to move the box by holding down the left mouse button. You can also move the edit box with the [Cursor keys]. Pressing [Shift] + [Cursor keys] moves the edit box in smaller increments, and pressing pressing [Ctrl] + [Cursor keys] moves it in larger increments.

Extend/compress box vertically

Move the motion cursor to the center of the top or bottom side of the box; the appearance of the cursor changes to a vertical arrow. Hold down the left mouse button and drag the box to the desired size. This function is available only when mode 1 is active.

Extend/compress box horizontally

Move the motion cursor to the center of the left or right side of the box; the appearance of the cursor changes to a horizontal arrow. Hold down the left mouse button and drag the box to the desired size. This function is available only when mode 1 is active.

Caution

**The content of the box is not modified proportionately. As a result, certain automatic objects become manual stitches. This response occurs in the following programs:
12, 13, 30, 31, 32 and 33.**

Edit box size

Move the motion cursor to a corner of the box; the appearance of the cursor changes to a sloping arrow. Hold down the left mouse button and drag the box corner to the desired size. The content of the box is modified proportionately. This function is available only when mode 1 is active.

Rotate

Move the rotation cursor to one corner of the box; the cursor is activated. If the cursor is not activated, click once on the bounding box. Hold down the left mouse button and rotate the box corner to the desired position. This function is available only when mode 2 is active.

Displace point of rotation

Click on the red dot depicting the point of rotation (not one of the corners) and, while holding down the left mouse button, drag it to the desired position. This function is available only when mode 2 is active.

Give box vertical slant

Move the cursor to the center of the top or bottom side of the box; the appearance of the cursor changes to a horizontal arrow. Hold down the left mouse button and drag the side of the box to the desired position. This function is available only when mode 2 is active.

Give box horizontal slant

Move the cursor to the center of the left or right side of the box; the appearance of the cursor changes to a vertical arrow. Hold down the left mouse button and drag the side of the box to the desired position. This function is available only when mode 2 is active.

Delete

Press [Delete] to delete the content of the edit box.

Copy



Press [F2] to copy the content of the edit box. The new edit box is placed around the copy of the data. All the functions of the edit box are now available.

Save



Press [F3] to save the content of the edit box as a block in the **Block manager**.

Tool box



Press [F4] to call the **Tool box**

Mirror on X axis



Press [F6] to mirror the content of the box horizontally. Specify the mirror axis with the cursor. To fix the mirror axis on an existing contour, press <Left> + [Shift].

If the option *As a copy* is selected in the **Tool box**, the original is retained. The edit box is placed around the copy.

Mirror on Y axis



Press [F7] to mirror the content of the box vertically. Specify the mirror axis with the cursor. To fix the mirror axis on an existing contour, press <Left> + [Shift].

If the option *As a copy* is selected in the **Tool box**, the original is retained. The edit box is placed around the copy.

Mirror on free axis



Press [F8] to mirror the content on a free axis. Specify the mirror axis by entering two points. To fix the mirror axis on an existing contour, press <Left> + [Shift]. The mirror axis is formed by the first and final point of the contour.

If the option *As a copy* is selected in the **Tool box**, the original is retained. The edit box is placed around the copy.

Selecting and deselecting "As a copy"



Press [F9] to switch "As a copy" on and off. (**Tool box**)

Extend selection



Press [F10] to extend the selection. If you omitted to include something in a selection or included too much, this function allows you to modify the original selection accordingly. **Single selection**

Numerical change



Press [F11] to change the size/position of the edit box by way of a numerical input. You can also edit the parameters of the edit box's content, such as the stitch distance. (**Numerical change**)

Color



Press [F12] to change the color of the drawing lines inside the edit box.

Tool box

Delete



This function deletes the contents of the edit box.

Copy



This function enables you to copy the content of the edit box. The new edit box is placed around the copy of the data. All the functions of the edit box are now available.

Save



This function enables you to save the content of the edit box as a block in the **Block manager**.

Center point

This function enables you to mark the center point of the edit box.

Mirror horizontally

This function enables you to mirror the content of the box horizontally. Specify the mirror axis with the cursor. To fix the mirror axis on an existing contour, press <Left> + [Shift].

If the option *As a copy* is selected, the original is retained; the edit box is placed around the copy.

Mirror vertically

This function enables you to mirror the content of the box vertically. Specify the mirror axis with the cursor. To fix the mirror axis on an existing contour, press <Left> + [Shift].

If the option *As a copy* is selected, the original is retained; the edit box is placed around the copy.

Mirror on free axis

This function enables you to mirror the content on a free axis. Specify the mirror axis by entering two points. To fix the mirror axis on an existing contour, press <Left> + [Shift]; the mirror axis is formed by the first and final point of the contour.

If the option *As a copy* is selected, the original is retained; the edit box is placed around the copy.

As a copy

If the option *As a copy* is selected, the original is retained when the mirror function is executed. The edit box is placed around the copy.

Rotate

With this function, the drawing lines of the edit box are arranged in a circle about a point of rotation. First define the point of rotation, then enter the number of elements.

Caution

This function operates only with drawing lines; punch data are ignored.

Divide

This function enables you to divide the drawing line into equal parts; enter the number of parts. The sections of the line are marked by short lines.

Caution

This function is not made available unless the edit box contains only one drawing line.

Spread

This function enables you to **Spread** the drawing lines of the edit box on one drawing line.

Caution

This function operates only with drawing lines; punch data are ignored.

Color

This function enables you to change the color of the drawing lines inside the edit box.

Change line type to design lines

This function converts all lines within the edit box to design lines.

Change line type to remarks

This function converts all lines within the edit box to remarks.

Change line type to help lines

This function converts all lines within the edit box to help lines.

Spread**General information**

The content of the edit box is spread on a distribution line that follows the contour. The base point determines the starting point of the object that is to be spread or distributed.

Caution

Only the drawing lines within the edit box are taken into account.

Spread with fixed No. (type 1)

You determine the number of objects to be spread. The specified number of objects are spread on the distribution line. The spacing between the objects is determined by the length of the distribution line and the number of objects.

Spread with definable object width (type 2)

You determine the object width. The number of spread objects is calculated according to the specified object width. If the "size adaptation" option is selected, the specified object width is adjusted so that a whole number of objects can be spread along the distribution line.

Spread with original object width (type 3)

The object width is determined by the span of the object in the X direction. The number of spread objects is calculated according to the object width. If the "size adaptation" option is selected, the specified object width is adjusted so that a whole number of objects can be spread along the distribution line.

Size adaptation

This function is available only with distribution types 2 and 3. If the "size adaptation" option is selected, the specified object width is adjusted so that a whole number of objects can be spread along the distribution line.

End height

The end height you specify determines the height of the final spread object. This parameter is available only with distribution type 1. The height and width of the objects are continuously adjusted from the initial to the final size.

Number of objects

Use this parameter to specify the number of objects to be spread. It is available only with distribution type 1.

Object width

Use this parameter to specify the object width. It is available only with distribution type 2.

Growth factor

The growth factor you specify determines the percentage difference in size between adjacent objects. This parameter is available only with distribution types 2 and 3. If the "size adaptation" option is selected, the entered value is automatically adjusted so that a whole number of objects can be spread along the distribution line.

Offset angle



If this option is not selected, all the objects are located perpendicular to the line. The pivot for tilting the object is formed by its base point. If the option is selected, the object is rotated about the base point by the offset angle of your choice. The same attitude is assumed by all the spread objects.

Numerical change

Expansion

X axis



You can adjust the width of the edit box either in per cent or absolutely. If you change one value, the other is automatically modified accordingly.

Y axis



You can adjust the height of the edit box either in per cent or absolutely. If you change one value, the other is automatically modified accordingly.

Caution

If you wish to adjust the span of the edit box proportionally, the *Proportional* function has to be selected.

If the content of the box is not modified in proportion, certain automatic objects become manual stitches. This response occurs in the following programs:

12, 13, 30, 31, 32 and 33.

Angle

Angle



This parameter enables you to rotate the edit box about the point of rotation.

Mirror

Mirror on X axis



This function enables you to mirror the content of the box horizontally. Specify the mirror axis with the cursor. To fix the mirror axis on an existing contour, press <Left> + [Shift].

Mirror on Y axis



This function enables you to mirror the content of the box vertically. Specify the mirror axis with the cursor. To fix the mirror axis on an existing contour, press <Left> + [Shift].

Distort

Top



This function enables you to distort the content of the box at the top edge.

Left



This function enables you to distort the content of the box at the left edge.

Block factors

Stitch distance



This parameter enables you to edit the stitch distance of the objects contained in the edit box in per cent.

Move in X direction



This parameter enables you to shift the edit box horizontally by the input value.

Move in Y direction



This parameter enables you to shift the edit box vertically by the input value.

Suchen und Ersetzen Sonderfunktion

Mit diesem Dialog können Sie Sonderfunktionen im Muster oder Musterbereichen suchen und ersetzen.

Dieser Dialog hat zwei Arbeitsmodi:

- Bestimmung der zu suchenden Sonderfunktion
- Bestimmung der ersetzenden Sonderfunktion

Generelle Vorgehensweise:

Zuerst ist die zu suchende, dann die ersetzende Sonderfunktion zu bestimmen.

Bestimmung der zu suchenden Sonderfunktion

Bei Aufruf des Dialoges sind nur die im Muster oder gewählten Musterbereich enthaltenen

Sonderfunktionen wählbar. Zuerst ist eine zu suchende Sonderfunktion auszuwählen. Bei Sonderfunktionen, für die weitere Parameterangaben erforderlich sind, öffnet sich ein weiterer Dialog, um diese Werte einzugeben. Bevor Sie mit *Weiter* bestätigen, um die ersetzende Sonderfunktion zu bestimmen, können Sie mit dem Knopf unter Optionen wählen, ob bei der Menge der ersetzenden Sonderfunktionen nur diejenigen wählbar gemacht werden sollen, die zur suchenden Sonderfunktion passen, d.h. die Sinn machen.

Bestimmung der ersetzenden Sonderfunktion

Aus den wählbaren Sonderfunktionen können Sie eine auswählen. Auch hier können, falls erforderlich, zusätzliche Parameterwerte in einem separaten Dialog eingegeben werden. Mit *Zurück* kommen Sie in den Arbeitsmodi zur Bestimmung der zu suchenden Sonderfunktion. Mit *Ersetzen* starten Sie das Suchen und Ersetzen. Hierbei wird die Einstellung zur *Abfrage beim Suchen und Ersetzen* berücksichtigt.

Einstellung mit/ohne Abfrage beim Suchen und Ersetzen im Muster/Musterbereich



Durch diesen Knopf unter Optionen können Sie bestimmen, ob beim Suchen und Ersetzen im Muster/Musterbereich eine Nachfrage zur Bestätigung erfolgen soll. Diese Einstellung ist unter beiden Modi möglich.

Bemerkung

Es können auch Marker gesucht und ersetzt werden.

Abfrage Suchen und Ersetzen

Bei der Abfrage auf Ersetzen haben Sie an Möglichkeiten:

- *<Links>*: Die markierte Sonderfunktion nicht ersetzen. Danach wird die nächste Sonderfunktion, falls vorhanden, gezeigt.
- *<Rechts>*: Die markierte Sonderfunktion ersetzen. Danach wird die nächste Sonderfunktion, falls vorhanden gezeigt.
- *[F3]*: Abbrechen des Vorgangs.
- *[F4]*: Ab jetzt alle weiteren Sonderfunktionen ohne Nachfrage ersetzen.
- *[Cursortasten]*: Die vorherige bzw. nächste Stelle mit einer gefundenen Sonderfunktion zeigen.

Global edit

General information

This on-screen dialog enables you to check and, if necessary, edit the stitch calculation parameters. Various methods are available. You can edit the key parameters directly, such as distance (coverage of filling) and pull compensation (equalization of thread tension to avoid distortion in the embroidery). The other parameters are governed by the parameter sets.

Proceed as follows:

Enter the modification parameters. You can edit the value either absolutely or in per cent.

State the program type and parameter sets in the "parameter sets" box. You can restrict the selection by way of the filter function if you wish.

Initiate the substitution routine with *Perform changes*.

During the substitution routine you are asked to confirm or reject the modification for each individual object.

Modification parameters

Set distance to



This parameter enables you to allocate a fixed distance value to the selected objects.

Distance %



This parameter enables you to change the distance values of the selected objects in per cent.

Set width to



This parameter enables you to set the border width of the satin stitch objects based on a center line to a new value.

Width %



This parameter enables you to enter a percentage change to the border width of the satin stitch objects based on a center line.

Pull compensation %



This parameter enables you to set the *Pull compensation* of the satin stitch and step stitch objects to a new value. The existing entry in the parameter sets for *Pull compensation* is substituted by the new value. This operation can give rise to new parameter sets if not all of the objects that use a common parameter set are to be modified.

Limit 1/10 mm



This parameter enables you to set the *Limit* parameter of the satin stitch and step stitch objects to a new value. The existing entry in the parameter sets for *Limit* is substituted by the new value. This operation can give rise to new parameter sets if not all of the objects that use a common parameter set are to be modified.

Miter overlap



This parameter enables you to set the overlap of the miter corners in satin stitch objects to a new value.

Change DPS with



You can specify a parameter set that you wish to use in place of another parameter set. You can also change the program within the satin stitch family. You can, for example, replace program 1 / parameter set 5 with program 3 / parameter set 8. To make this change, first enter **3.8** in the box, then click box **1.5** in the parameter set matrix.

Exchange block with



You can specify the new block in the block manager. Then in the matrix click the parameter sets in whose objects the block is to be exchanged.

Reset

Press *Reset* to cancel the modification operation; all the boxes are cleared.

Parameter sets

The parameter set matrix contains all of the sets that are used in the current design. You can restrict the selection with the *Filter function*. The selection is also restricted by the parameters that are to be edited. The parameter *Pull compensation*, for example, is contained only in the parameter sets of the satin stitch and step stitch objects. The parameter sets of these programs are thus depicted only if you wish to modify the pull compensation.

If the parameter sets used in a program cannot be displayed in one row, you can scroll through the options with *>>*. When you reach the end, the display jumps back to the start of the row.

The monogram program type (33, 34) is a special case. The objects in this program type do not have any parameter sets. They can be selected only as whole objects.

Parameter sets used in a chaining program (13, 31, 32, 33) are designated 12* . 12*.

Specifying the parameter sets to be edited

Click the parameter sets you wish to modify. If you wish to modify all the objects in a certain program type, click the number of the program (column 1). If you wish to modify all the objects in the design, click *Prg*.

Edit design parameter sets (DPS)

Clicking *Edit design parameter sets (DPS)* takes you to the input routine for the *Parameter set*. Once you have made the desired change, press *Save* and select the parameter set number in the matrix above the parameter set.

Filter

The filter function comprises two parts. You can specify, by way of the needle color, which objects are to be affected by the change. In addition, the dialog *Global-Edit Filter* allows you, by way of parameters, to specify which parameter sets are to be shown in the matrix alongside. Restricting the selection in this way can make your work easier.

Design Info

Total of stitches

The total number of stitches in the design.

Manual stitches

The number of manual stitches in the design.

Stitches in objects

The number of object stitches.

Actions

Perform changes

Once you have stated all the changes you wish to make and specified the parameter sets, you can determine whether the modification is to be executed without any further inquiry. Click the box that follows the new parameter setting; two settings are available:



No inquiry.



You decide for each object individually whether or not the set changes are to be implemented.

With the second option, the operation is halted before each affected object. Pressing <Left> bypasses the object; no modification is made. Press <Right> if you wish the object to be modified. Pressing [F3] terminates the pass immediately; the modifications that have already been accepted remain valid. Pressing [F4] deselects the inquiry with the effect that all subsequent objects are modified.

Calculate design

The stitch calculation is performed again for all objects. This is essential in some cases, typically if a parameter set that is used in several objects was modified for one particular object. If the modification is to apply to the other objects as well, the design has to be recalculated.

Edit objects

This function enables you to call the object editor for certain objects one after the other. The modification parameter box must be empty. If it does contain an entry, press *Reset*. Select the parameter sets in the parameter set matrix as described above. Press *Edit objects*. In the pass that follows, pressing <Left> bypasses the object, and <Right> calls the editor for the object in question. Pressing [F3] terminates the pass immediately; the modifications that have already been accepted remain valid.

Resolve objects

This function enables you to resolve the selected objects into manual stitches. The modification parameter box must be empty. If it does contain an entry, press *Reset*. Select the parameter sets in the parameter set matrix as described above. Press *Resolve objects*. Once you confirm the safety inquiry, the objects are resolved into manual stitches.

Global edit filter

With the exception of *Distance* and *Width*, the individual parameters form part of a parameter set. Click the parameter by means of which you wish to restrict the selection of parameter sets. Enter the value range. The *Jagged* parameter offers only the options *Yes* and *No*. When you confirm the on-screen dialog with *OK*, the parameter sets that are outside the value range are eliminated by filtering. Pressing *Reset* reactivates the default setting.

Block list

The block list displays the current design in a different form. According to the rules that apply to the *Block filter*, the design is divided into individual blocks and displayed in a chronological embroidery

sequence in separate windows. The block list serves two purposes: to simplify selection, and for altering the sequence of embroidering.

The block list is displayed in two different ways. The standard view is a "film strip" along the left edge of the working window. The number of windows that can be displayed at once depends on the resolution of the screen. The remaining area of the working window displays the design in the usual form. The other block list view is the "slide show", which occupies the entire working window. The design displayed in the working window is masked by the slide show.

Switch on the block list in **View** and activate it with **[Alt]** or **[F]**. When the block list is activated, the form of the cursor changes from a cross-hair pointer to an arrow. You can now make selections only in the block list. Pressing **[Alt]** again deactivates the block list.

When a block is selected, a frame in the selection color (yellow) is traced around the relevant window. At the same time the stitches that constitute the block are drawn in the selection color in both the block window and the working window.

Block list functions

Press **<Left>** to select a single block.

Press **[Strg] + <Left>** to select a succession of individual blocks, thus forming a selected lot.

Selecting a marked block again with **[Strg] + <Left>** has the effect of eliminating it from the current selected lot.

Pressing **[Shift] + <Left>** on a block eliminates all the previously selected blocks from the selected lot. The new block constitutes the (upper or lower) limit of an embroidery area. Executing the same operation on another block concludes the area formation exercise.

Use **[Strg] + <Left>** to modify the selected lot of elements; that is to say, to eliminate or add single blocks.

Pressing **[Return]** or **<Right>** confirms the selection and takes you to the appropriate edit box in the working window.

You can scroll forwards and backwards through the block list by pressing the cursor keys **[Down]** and **[Up]**. Each current block is selected in turn. Holding down **[Shift]** at the same time has the effect of forming a selected lot of blocks.

You can scroll more quickly (in larger steps) through the block list by pressing **[Page down]** and **[Page up]**; no blocks are selected.

Pressing **[Home]** takes you to the start of the block list, and pressing **[End]** takes you to the end of the list.

Pressing **[Delete]** deletes the currently selected item from the design.

Pressing **[Strg] + [X]** deletes the currently selected item from the design and places it on the clipboard (block 1.1).

Pressing **[Strg] + [C]** places the currently selected item on the clipboard (block 1.1).

Pressing **[Strg] + [V]** deletes the currently selected item from the design and replaces it with the contents of the clipboard (block 1.1).

Shift block (drag & drop).

View



Use **[F2] View** to influence the way in which the design is displayed; you can, for example, eliminate all stitches of a certain color from the display. Note that blocks cannot be selected in the block list if stitches have been masked with the "View" function. Such blocks are depicted in the dim color in the block list.

"Film strip" / "Slide show"

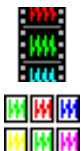

Pressing [F3] switches between the two forms of displaying the block list.

Alternative block shift



Press [F4] to initiate the alternative block shift function. All the blocks that constitute the design are displayed in the "slide show". Press <Left> to select a succession of single blocks in the sequence in which you wish them to be embroidered. Pressing [Backspace] reverses the last selection. Press [Return] to conclude the block shift operation. Any blocks that were not selected are appended to those that were without changing the order of the unselected blocks. The selected blocks are shown in the overview window.

Refresh



Pressing [F5] updates the display of the block list; selected items remain selected.

Move block to



Press [F6] and enter a number to move the selected blocks. The existing block with the destination number and the following blocks are move forward to make room for the number of blocks that have been selected. Use *Start of design* to shift the selected blocks to the start of the design, and *End of design* to shift them to the end of the design.

Block filter



Press [F7] to reset the **Block filter**; the block list is reconstituted according to the revised rules.

Block animation



Press [F8] to run an animation of the blocks. The design is centered and drawn in gray. The individual blocks are drawn consecutively in the relevant needle color. Before the animation starts, a dialog allows you to enter the interval duration as a numerical value in the range 1 to 1000 msec. *Animation* resumes the animation, and *Cancel* aborts it. Pressing the [Space bar] interrupts the animation. This dialog appears in this case as well.

Shift block (drag & drop)

This function enables you to alter the sequence in which the blocks that constitute a design are embroidered. First select the blocks you wish to relocate. Hold down the left mouse button and drag the selected blocks to the destination. Release the mouse button once the blocks are in the desired position, where they are integrated. If the statuses of the special functions are inappropriate for the newly created block interfaces, an adjustment is made by incorporating special functions.

If you exit the block list with the shift cursor, it becomes a prohibiting symbol. If you release the left mouse button now, the selected blocks remain in their original position. If you wish to shift blocks, you have to make a new selection.

If you move the cursor to the top edge of the block list, the list scrolls down automatically; it scrolls up if you move the cursor to the bottom edge.

Drawing

Alongside the (scanned) images, the drawing elements created with the drawing function serve as the foundation for creating objects by punching.

Once the drawing function has been called, you can enter drawing lines directly. These are the lines that belong to the design; they are independent of the punch data. They serve as an aid to creating the outlines or contours of objects or manual stitches.

For more information on entering drawing lines, see [Contour](#).

Block function



Press [F3] to start the [Block function](#).

Contour mode



Press [F4] to change the contour mode (see [Contour](#)).

Editor



Press [F6] to start the [Editor](#).

Geometry



Press [F7] to call the on-screen dialog for selecting [Geometry](#).

Punching



Press [F8] to start [Manual punching](#).

Parallels



Press [F9] to switch the parallel mode on/off (also see [Contour](#)).

Stitch direction marker



Press [F10] to switch to the screen for entering [Stitch direction markers](#).

Line color



Press [F12] to change the line color; all lines are subsequently drawn with the selected color.

Stitch direction marker

The stitch direction marker is a line with two end points. Enter the line by consecutively defining two points with <Left>. You can continue entering stitch direction markers until terminating the operation with [Return]. Once you have entered this confirmation, the entered stitch direction markers are cut off at the existing drawing lines provided that the stitch direction marker intersects two contours. Pressing [Esc] closes the stitch direction marker input operation; you have to confirm your wish to abort in an on-screen dialog.

Line color



Press [F12] to change the line color.

Geometry

Besides lines, geometric forms are also available as drawing elements. Select the individual forms by pressing <Left> on the appropriate button. The following options are available:

- Circle
- Arc
- Ellipse
- Ellipse (Angle)
- Polygon
- Rectangle
- Rectangle (Angle)
- Rectangle (R)
- Rectangle (R) (Angle)
- Spiral

Shortcuts are also available in this dialog; for further information see [Terms and background information](#).

If the function *Mark center point* is set, a center point is drawn together with the depiction of the created geometric form.

Note :

The center point is a separate drawing element. When a geometric form is selected by way of a single selection in the editor, therefore, the center point is not selected as well. The center point consists of two intersecting drawing lines, each of which can be selected individually.

After confirming the selection with *OK*, you can enter the desired geometric element.

Circle

You enter a circle by first defining the center point with <Left>. The second <Left> determines the radius of the circle.

Use <Left> + [Shift] to approach an existing drawing line or the grid.

Press [Return] to create a circle with the default value, taking the cursor position as the center point
Pressing [Esc] closes the circle input routine.

Edit-Box



Press [F3] to load the most recently entered geometric form to the Edit box.

Geometry



Press [F7] to select a new geometric form.

Numerical input



Press [F11] to define the size of the circle by way of a number input.

Line color



Press [F12] to change the drawing color.

Arc

You enter an arc by consecutively entering three points with <Left>. You can create a circle with this function as well, by pressing <Left> + [Strg] instead of entering the third point with <Left>. Use <Left> + [Shift] to approach an existing drawing line or the grid.

Pressing [Esc] closes the arc input routine.

Edit box



Press [F3] to load the most recently entered geometric form to the Edit box.

Geometry



Press [F7] to select a new geometric form.

Line color



Press [F12] to change the drawing color.

Ellipse

You enter an ellipse by first defining the center point with `<Left>`. The second `<Left>` determines the size of the ellipse.

Use `<Left>` + `[Shift]` to approach an existing drawing line or the grid.

Press `[Return]` to create an ellipse with the default value, taking the cursor position as the center point.

Pressing `[Esc]` closes the ellipse input routine.

Edit box



Press `[F3]` to load the most recently entered geometric form to the **Edit box**.

Geometry



Press `[F7]` to select a new geometric form.

Numerical input



Press `[F11]` to define the size of the ellipse by way of a number input.

Line color



Press `[F12]` to change the drawing color.

Ellipse (Angle)

You enter an ellipse with angle by first defining the position; enter two points with `<Left>`. The third `<Left>` determines the size of the ellipse.

Use `<Left>` + `[Shift]` to approach an existing drawing line or the grid.

Pressing `[Esc]` closes the ellipse input routine.

Edit box



Press `[F3]` to load the most recently entered geometric form to the **Edit box**.

Geometry



Press `[F7]` to select a new geometric form.

Line color



Press [F12] to change the drawing color.

Polygon

You enter a polygon by first defining and confirming the number of corners in an on-screen-dialog. Then enter the center point with <Left>. The second <Left> determines the size of the polygon.

Use <Left> + [Shift] to approach an existing drawing line or the grid.

Press [Return] to create a polygon with the default value, taking the cursor position as the center point.

Pressing [Esc] closes the polygon input routine.

Edit box



Press [F3] to load the most recently entered geometric form to the **Edit box**.

Geometry



Press [F7] to select a new geometric form.

Numerical input



Press [F11] to define the size of the polygon by way of a number input.

Line color



Press [F12] to change the drawing color.

Rectangle

You enter a rectangle by defining two corners with <Left>.

Use <Left> + [Shift] to approach an existing drawing line or the grid. You can create a square with <Left> + [Strg].

Press [Return] to create a rectangle with the default value at the cursor position.

Pressing [Esc] closes the rectangle input routine.

Edit box



Press [F3] to load the most recently entered geometric form to the **Edit box**.

Geometry



Press [F7] to select a new geometric form.

Numerical input



Press [F11] to define the size of the rectangle by way of a number input.

Line color



Press [F12] to change the drawing color.

Rectangle (Angle)

You enter a rectangle with angle by first defining the position; enter two points with <Left>. The third <Left> determines the size of the rectangle.

Use <Left> + [Shift] to approach an existing drawing line or the grid.

Pressing [Esc] closes the rectangle input routine.

Edit box



Press [F3] to load the most recently entered geometric form to the Edit box.

Geometry



Press [F7] to select a new geometric form.

Line color



Press [F12] to change the drawing color.

Rectangle (R)

First enter the radius of the rounded corners. Then define the size of the rectangle by defining two corners with <Left>.

Use <Left> + [Shift] to approach an existing drawing line or the grid. You can create a square with <Left> + [Strg].

Press [Return] to create a rectangle with the default value at the cursor position.

Pressing [Esc] closes the rectangle input routine.

Edit box



Press [F3] to load the most recently entered geometric form to the **Edit box**.

Geometry



Press [F7] to select a new geometric form.

Numerical input



Press [F11] to define the size of the rectangle by way of a number input.

Line color



Press [F12] to change the drawing color.

Rectangle (R) (Angle)

First enter the radius of the rounded corners. Then define the position of the rectangle by defining two corners with <Left>. The third <Left> determines the size of the rectangle.

Use <Left> + [Shift] to approach an existing drawing line or the grid.

Pressing [Esc] closes the rectangle input routine.

Edit box



Press [F3] to load the most recently entered geometric form to the **Edit box**.

Geometry



Press [F7] to select a new geometric form.

Line color



Press [F12] to change the drawing color.

Spiral

First define the spiral parameters.

Space



This parameter determines the clearance between spiral lines.

Corners



This parameter defines the number of corners in the spiral. Entering *0* creates a spiral without any corners.

Clockwise



This parameter defines the direction of rotation of the spiral.

Fix the center, start and end points of the spiral with <Left>.

Use <Left> + [Shift] to approach an existing drawing line or the grid.

Pressing [Esc] closes the spiral input routine.

Edit box



Press [F3] to load the most recently entered geometric form to the **Edit box**.

Geometry



Press [F7] to select a new geometric form.

Line color



Press [F12] to change the drawing color.

Monogram TrueType fonts

This program enables you to spread or space lettering on a line using the TrueType fonts available under Windows.

First select the font. The dialog that follows allows you to enter the text, necessary parameters and form of distribution.

Pressing **OK** takes you to the dialog for entering the distribution line (see **Contour**). Once you have entered the contour, the lettering is calculated. Press **Yes** if you wish to accept the outcome. Pressing **No** enables you to modify the parameters and text.

Note

Once you have accepted the result by pressing **Yes**, you can no longer make any changes to the parameters or text. The result is converted to drawing lines; these can be modified individually.

Font

You can use only one font per object. Select the one you wish to use with [<Left>](#).

Text

You can enter the monogram text in the box provided. As an alternative when entering a text for the first time, you can write the text on the contour line; in this case, pressing [\[Return\]](#) terminates the entry. Corrections must be made in the input box; click the relevant location in the text in the input box and edit the incorrect characters.

General parameters

Character height

AI

This is where you set the height of the lettering for the current object. Note that this parameter determines the basic height of the text. All the letters are enlarged or reduced on the same scale.

Character width

A %

At 0%, the width of the character is calculated to be correct in proportion to its height. Values less than 0 create characters that are relatively narrow, and values greater than 0 characters that are relatively broad. The spacing between the characters is modified according to the set width, but only if [Spread automatically](#) is selected.

Character distance

ABC

You can manipulate the character spacing here. Values greater than 0 increase the spacing, and values less than 0 move the individual characters closer together. The character width is modified according to the set spacing, but only if [Spread automatically](#) is selected.

Spreading parameters

Spread on line

ABC

The lettering is distributed on a contour created with [Contour](#). If this function is selected, you write on a horizontal line from left to right, starting from the preceding stitch. Press [\[Return\]](#) to conclude the input; only [Left-justified](#) is made available.

Left-justified

ABC

The lettering is left-justified on the contour on which the text is spread.

Right-justified

ABC

The lettering is right-justified on the contour on which the text is spread.

Centered

ABC

The lettering is centered on the contour on which the text is spread.

Spread automatically

A B C

The lettering is spread to utilize the full length of the contour. The character spacing is uniformly adjusted. This adjustment is also made if the width or spacing of individual characters is edited.

Zeichnen Automatikprogramme

- Zugeffekte
- Fülleffekte
- Bohreffekte
- Sonstige Zeichenprogramme

Zugeffekte

Aufteilungslinie

Die Aufteilungslinie geben Sie mit der **Konturbildung** ein.

Objekthöhe

Nach Eingabe der Aufteilungslinie bestimmen Sie die Objekthöhe. Diese können Sie grafisch mit **<Links>** oder numerisch eingeben. Bei der numerischen Eingabe stehen Ihnen zwei Möglichkeiten zur Verfügung:

- **[F8]** Parametersatz (allgemeine Parameter und objektbezogene Parameter)
 - Rand
 - Doppelter Rand
 - Bohrstäffel
 - Zugstäffel
 - Doppelter Zugstäffel
 - Zughöhl
- **[F11]** Objektbezogene Parameter
 - Rand
 - Doppelter Rand
 - Bohrstäffel
 - Zugstäffel
 - Doppelter Zugstäffel
 - Zughöhl

Parameter border

Border width



0.1-999 mm

Enter border width here.

Colors



Pressing *Colors* initiates a dialog that enables you to set the *Colors* of the object.

Double border parameters

Proportional



Here you can determine whether the two borders are to have the same width. If the option is selected, the second value is automatically edited to comply with the first.

Border width 1



0.1 - 999 mm

Enter border width 1 here.

Border width 2



0.1 - 999 mm

Enter border width 2 here.

Colors



Pressing *Colors* initiates a dialog that enables you to set the *Colors* of the object.

Bohrstafel parameters

Object height



Enter the object height here.

Object width



Enter the object width here.

Width



0.1 - 999 mm

Enter the border width here.

Colors



Pressing *Colors* initiates a dialog that enables you to set the *Colors* of the object.

Parameter Zugstafel

Object height



Enter the object height here.

Object width



Enter the object width here.

Width



0.1-999 mm

Enter the border width here.

Stichdistanz



0.1-99 1/10mm

Die Stichdistanz stellen Sie hier ein.

Aufteilungslinie



50-100%

Die Position der Aufteilungslinie stellen Sie hier ein. Mit ihr konnen Sie festlegen, wo die Objektbreite gemessen werden soll. Bei 50% wird in der Mitte gemessen. Bei 100% wird am Ende der Beine

gemessen.

Spiegeln



Hier legen Sie fest, ob die Beine an der Grundlinie gespiegelt werden sollen.

Colors



Pressing *Colors* initiates a dialog that enables you to set the *Colors* of the object.

Double zugstüffel parameters

Object height



Enter the object height here.

Object width



Enter the object width here.

Colors



Pressing *Colors* initiates a dialog that enables you to set the *Colors* of the object.

Parameter Zughöhl

Object height



Enter the object height here.

Object width



Enter the object width here.

Colors



Pressing *Colors* initiates a dialog that enables you to set the *Colors* of the object.

Filling effects

The available filling effects are as follows:

Bohrhöhle
Wabenhöhle
Ziegelhöhle
Stoffhöhle
Grid filling

Each of the filling effects is created and edited in the same way. A closed or continuous contour must be defined first.

The following options are provided:

Define reference points for a filling effect object
 Reference point for filling
 Reference point in the design
Rotate a filling effect object
Change size of a filling effect object
Manual input of various parameters for a filling effect object
Manual input of a parameter set for a filling effect

Differences between creating and editing

When creating a new filling effect object, you are working in the mode that enables you to determine the reference point for the filling. Reference is made to preset values, such as the height and width of a segment. These are determined either upon installation or according to values previously entered when a filling effect of the same type was created or edited.

The procedure for editing a filling effect starts with the selection of the type of manipulation you wish to perform.

General method of creating and editing filling effects

Select function

This option enables you to change between the individual modes:

[F3] for changing the segment size of the filling object
[F4] or <Left> for filling object reference points
[F6] for rotating the filling object

Pressing [ESC] ends the procedure for creating or editing a filling effect object without accepting any values, except that confirmed changes in the parameter set for the filling effect type are accepted.

Pressing [Return] accepts the settings you made and ends the procedure for creating or editing a filling effect object.

Reference point filling

Determine the reference point for the filling here with <Left> or [Shift] + <Left>. Pressing [Return] confirms the defaulted filling reference point. Pressing [ESC] closes this mode and takes you back to the choice of functions. This reference point serves as an anchor point for determining the reference point for the filling in the object. Confirming the reference point takes you to the reference point object mode.

Reference point object

Once you have confirmed the reference point for the filling, determine the reference point for the filling of the filling effect object here with <Left> or [Shift] + <Left>. The cross-hair pointer is anchored to the reference point for the filling.

Change size

Here you can change the size of the filling effect object with the cursor keys. Holding down the [Ctrl] key at the same time enables you to enlarge and reduce the object in larger steps. Holding down the [Shift] key at the same time cancels the proportional size change option that is available for bohrhöhle and stoffhöhle.

Size change with cursor keys:

Left cursor key: horizontal reduction

Right cursor key: horizontal enlargement

Cursor key up: vertical reduction

Cursor key down: vertical enlargement

Pressing <Left> or [Return] confirms the size change and closes this mode.

Press [ESC] to close the mode without accepting the size change.

Rotate

Here you can rotate the filling effect object in increments by moving the mouse. While moving the mouse, hold down the [Shift] key to rotate in smaller increments or the [Ctrl] key to rotate in larger increments.

Pressing <Left> or [Return] confirms the set angle and closes this mode. This takes you back to the choice of functions.

Press [ESC] to close the mode without accepting changes to the angle. This takes you back to the choice of functions.

Options available with all modes (including "Select function")

[F8] for calling the parameter set dialog

Parameter set bohrhöhle

Parameter set wabenhöhle

Parameter set ziegelhöhle

Parameter set stoffhöhle

Parameter set grid filling

[F11] for calling the parameter dialog

Parameter bohrhöhle

Parameter wabenhöhle

Parameter ziegelhöhle

Parameter stoffhöhle

Parameter grid filling

Bohrhöhle parameters

This dialog enables you to set the individual parameters.

Object height



This number input field is provided for you to enter the height of an object in mm.

Object width



This number input field is provided for you to enter the width of an object in mm.

Angle of rotation



This number input field allows you to determine the angle (0 to 360 degrees) by which this filling effect is to be rotated about the reference point.

Colors



Pressing *Colors* initiates a dialog that enables you to set the *Colors* of the object.

OK

This button accepts the settings and closes the dialog.

Cancel

This button rejects the settings and closes the dialog.

Wabenhöhl parameters

This dialog enables you to set the individual parameters.

Object height



This number input field is provided for you to enter the height of an object in mm.

Object width



This number input field is provided for you to enter the width of an object in mm.

Angle of rotation



This number input field allows you to determine the angle (0 to 360 degrees) by which this filling effect is to be rotated about the reference point.

Colors



Pressing *Colors* initiates a dialog that enables you to set the *Colors* of the object.

OK

This button accepts the settings and closes the dialog.

Cancel

This button rejects the settings and closes the dialog.

Ziegelhöhl parameters

This dialog enables you to set the individual parameters.

Object height



This number input field is provided for you to enter the height of an object in mm.

Object width



This number input field is provided for you to enter the width of an object in mm.

Angle of rotation



This number input field allows you to determine the angle (0 to 360 degrees) by which this filling effect is to be rotated about the reference point.

Colors



Pressing *Colors* initiates a dialog that enables you to set the *Colors* of the object.

OK

This button accepts the settings and closes the dialog.

Cancel

This button rejects the settings and closes the dialog.

Stoffhöhl parameters

This dialog enables you to set the individual parameters.

Object height



This number input field is provided for you to enter the height of an object in mm.

Object width



This number input field is provided for you to enter the width of an object in mm.

Angle of rotation



This number input field allows you to determine the angle (0 to 360 degrees) by which this filling effect is to be rotated about the reference point.

Colors



Pressing *Colors* initiates a dialog that enables you to set the *Colors* of the object.

OK

This button accepts the settings and closes the dialog.

Cancel

This button rejects the settings and closes the dialog.

Grid filling parameters

This dialog enables you to set the individual parameters.

Object height



This number input field is provided for you to enter the height of an object in mm.

Object width



This number input field is provided for you to enter the width of an object in mm.

Angle of rotation



This number input field allows you to determine the angle (0 to 360 degrees) by which this filling effect is to be rotated about the reference point.

Colors



Pressing *Colors* initiates a dialog that enables you to set the *Colors* of the object.

OK

This button accepts the settings and closes the dialog.

Cancel

This button rejects the settings and closes the dialog.

Boring effects

The available boring effects are as follows:

Bored hole

Birnenloch

Cut bored hole

Rectangle bored hole

Each of the boring effects is created and edited in the same way. The following options are provided:

Move a boring effect object

Rotate a boring effect object

Edit the size of a boring effect object

Manual input of various parameters for a boring effect object

Manual input of a parameter set for a boring effect

Differences between creating and editing

When creating a new boring effect object, you are working in the mode that enables you to move the object. Reference is made to preset values, such as height and width. These are determined either upon installation or according to values previously entered when a boring effect of the same type was created or edited.

The procedure for editing a boring effect starts with the selection of the type of manipulation you wish to perform.

General method of creating and editing boring effects

Move

Here you can move the boring effect object in the design with the mouse. The cross-hair pointer is located at the intersection of the cross used for positioning the boring effect object.

[Shift] + <Left>: The boring effect object is placed in the design with the current parameter values at the snap position, and the creating or editing operation is terminated.

Pressing <Left> or [Return] confirms the current position and closes this mode.

Press [ESC] to close the mode without accepting the move.

Change size

Here you can change the size of the boring effect object by moving the mouse. When this mode is initiated, the cross-hair pointer is located in the bottom right corner of the object.

Pressing <Left> or [Return] confirms the size change and closes this mode.

Press [ESC] to close the mode without accepting the size change.

Rotate

Here you can rotate the boring effect object in increments by moving the mouse. While moving the mouse, hold down the [Shift] key to rotate in smaller increments or the [Ctrl] key to rotate in larger increments.

Pressing <Left> or [Return] confirms the rotation and closes this mode.

Press [ESC] to close the mode without accepting the rotation.

Select function

This option enables you to change between the individual modes:

[F3] for changing the size of the boring effect object

[F4] for moving the boring effect object

[F6] for rotating the boring effect object

[F8] for calling the parameter set dialog

Parameter set bored holeID_Bohrloch

Parameter set birnenlochID_Birnenloch

Parameter set cut bored holeID_Schneidloch

Parameter set rectangle bored holeID_Bohr_Rechteck

[F11] for calling the parameter dialog

Parameters bored hole

Parameters birnenloch

Parameters cut bored hole

Parameters rectangle bored hole

Pressing [ESC] ends the procedure for creating or editing a boring effect object without accepting any values, except that changes in the parameter set dialog that were confirmed with *OK* are accepted.

<Left> or [Return]: The boring effect object is placed in the design with the current parameter values at the current position, and the creating or editing operation is terminated.

Pressing [ESC] ends the procedure for creating or editing a boring effect object without accepting any values, except that confirmed changes in the parameter set for the boring effect type are accepted.

Bored hole parameters

This dialog enables you to define the settings for the bored hole.

Diameter



This number input field is provided for you to enter the outside diameter of the bored hole in mm.

Cross dist. from border

This number input field is provided for you to determine the spacing from the ends of the cross to the inside edge of the bored hole border in mm.

Width



This number input field is provided for you to enter the border width of the bored hole in mm.

Cross rotation



This number input field allows you to determine the angle (0 to 360 degrees) by which the bored hole cross is to be rotated.

Bored hole angle of rot.



This number input field allows you to determine the angle (0 to 360 degrees) by which the bored hole is to be rotated.

Colors



Pressing *Colors* initiates a dialog that enables you to set the *Colors* of the object.

OK

This button accepts the settings and closes the dialog.

Cancel

This button rejects the settings and closes the dialog.

Birnenloch parameters

This dialog enables you to define the settings for the birnenloch.

Height



This number input field is provided for you to enter the height of the birnenloch in mm.

Width



This number input field is provided for you to enter the width of the birnenloch in mm.

Crossbar dist. from border

This number input field is provided for you to determine the spacing from the ends of the crossbar to the inside edge of the birnenloch border in mm.

Upright dist. from border

This number input field is provided for you to determine the spacing from the ends of the upright to the inside edge of the birnenloch border in mm.

Width



This number input field is provided for you to enter the border width of the birnenloch in mm.

Semi-circle center offset

This number input field enables you to edit the semicircle that forms the top of the birnenloch. The percentage entered here, representing the distance from the center of the birnenloch to its top edge, determines the position of the semicircle. Moving the semicircle changes the position of the crossbar, which is generally situated at the calculated center of the circle. Exception: If the calculated center is below the center point of the birnenloch, the crossbar is positioned at the same height as the notional line forming the diameter of the circle.

Horiz. points for b. shape

The number entered here determines the horizontal position of two reference points for the border of the birnenloch. These points influence the shape of the birnenloch. The percentage value represents the distance from the horizontal center to the outside edge of the birnenloch.

Vert. points for b. shape

The number entered here determines the vertical position of two reference points for the border of the birnenloch. These points influence the shape of the birnenloch. The percentage value represents the distance from the vertical center to the vertical center point of the birnenloch.

Cross rotation



This number input field allows you to determine the angle (0 to 360 degrees) by which the birnenloch cross is to be rotated.

Birnenloch rotation



This number input field allows you to determine the angle (0 to 360 degrees) by which the birnenloch is to be rotated.

Colors



Pressing *Colors* initiates a dialog that enables you to set the *Colors* of the object.

OK

This button accepts the settings and closes the dialog.

Cancel

This button rejects the settings and closes the dialog.

Rectangle bored hole parameters

This dialog enables you to define the settings for the rectangular bored hole.

Height



This number input field is provided for you to enter the outside diameter of the rectangular bored hole in mm.

Cross dist. from border

This number input field is provided for you to determine the spacing from the ends of the cross to the inside edge of the rectangular bored hole border in mm.

Width



This number input field is provided for you to enter the border width of the rectangular bored hole in mm.

Cross rotation



This number input field allows you to determine the angle (0 to 360 degrees) by which the rectangular bored hole cross is to be rotated.

Rect. bored hole rotation



This number input field allows you to determine the angle (0 to 360 degrees) by which the rectangular bored hole is to be rotated.

Colors



Pressing *Colors* initiates a dialog that enables you to set the *Colors* of the object.

OK

This button accepts the settings and closes the dialog.

Cancel

This button rejects the settings and closes the dialog.

Parameter Schneidloch

Mit diesem Dialog können Sie die Einstellungen für das Schneidloch vornehmen.

Höhe



Mit diesem Zahleneingabefeld können Sie die Höhe des Schneidlochs in mm angeben.

Breite



Mit diesem Zahleneingabefeld können Sie die Breite des Schneidlochs in mm angeben.

hor. Kreuzabstand v. Rand

Mit diesem Zahleneingabefeld können Sie den Abstand der Enden des horizontalen

Schneidlochkreuzbalkens von der Innenkante des Schneidlochrandes in mm bestimmen.

ver. Kreuzabstand v. Rand

Mit diesem Zahleneingabefeld können Sie den Abstand der Enden des vertikalen Schneidlochkreuzbalkens von der Innenkante des Schneidlochrandes in mm bestimmen.

Randbreite



Mit diesem Zahleneingabefeld können Sie die Randbreite des Schneidlochs in mm angeben.

Drehwinkel Kreuz



Mit diesem Zahleneingabefeld können Sie bestimmen, um wieviel Grad (0 bis 360) das Schneidlochkreuz gedreht werden soll.

Drehwinkel Schneidloch



Mit *Farben* wird ein Dialog gestartet, in dem Sie die *Farben* des Objektes einstellen können.

Farben



Mit diesem Knopf wird ein weiterer Dialog gestartet, mit dem Sie die Farben für das Birnenloch (Kreuz, Rand) bestimmen können.

OK

Mit diesem Knopf wird der Dialog mit Übernahme der Einstellungen beendet.

Abbrechen

Mit diesem Knopf wird der Dialog ohne Übernahme der Einstellungen beendet.

Sonstige Automatikzeichenprogramme

- Zeichenprogramm Stichlagen
- Kreuzbollen
- Rapport
- True-Type Monogramm
- Wickellinie

Stitch direction marker

The stitch direction marker is a line with two end points. Enter the line by consecutively defining two points with `<Left>`. You can continue entering stitch direction markers until terminating the operation with `[Return]`. Once you have entered this confirmation, the entered stitch direction markers are cut

off at the existing drawing lines provided that the stitch direction marker intersects two contours. Pressing [Esc] closes the stitch direction marker input operation; you have to confirm your wish to abort in an on-screen dialog.

Line color



Press [F12] to change the line color.

Cross boll parameters

Circle

Enter the first, second and third points with <Left>.

Parameters

The parameters for the cross boll are described under [Parameter set cross boll](#).

Parameter Rapport

Mit diesem Programm werden alle Designlinien im gewählten Abstand links und rechts vom Hauptrapport rapportiert. Ausgenommen sind Linien, die mit Hilfe der Funktion [Rapportkopie](#) in [Tool Box](#) im individuellen Rapport kopiert wurden.

Multi-Head Muster

Kopfabstand

Hier geben Sie den Rapportabstand in mm an. In der Regel ist dies der Kopfabstand, den Sie im Musterkopf angeben.

Schiffli Muster

Rapport

Hier geben Sie den Rapportabstand in /4 an.

Mit Stiche

Durch anklicken dieser Option werden berechnete Stiche der Automatikzeichenprogramme mit rapportiert.

Mit Stichlagen

Durch anklicken dieser Option werden Stichlagen mit rapportiert.

Mit Hilfslinien

Durch anklicken dieser Option werden Hilfslinien mit rapportiert.

Mit Kommentartext

Durch anklicken dieser Option werden Kommentartexte mit rapportiert.

Mit Marker

Durch anklicken dieser Option werden Marker mit rapportiert.

Rapport löschen

Die Funktion *Rapport löschen* löscht alle rapportierten Linien. Wurden in diesem Muster individuelle Rapporte mit der Funktion *Rapportkopie* in *Tool Box* erstellt, können Sie diese auch löschen, wenn Sie die anschließende Abfrage mit *Ja* bestätigen.

Parameter True-Type Monogramm

Mit diesem Programm können Sie einen Schriftzug auf einer Linie verteilen. Dabei können Sie die TrueType-Schriftarten Ihrer Windows-Installation verwenden.

Geben Sie zunächst die *Aufteilungslinie mit der Konturbildung* ein. Bestimmen Sie danach die Schriftart. Im folgenden Dialog geben Sie den Text ein und bestimmen die notwendigen Parameter und die Aufteilungsform.

Mit *OK* wird der Schriftzug berechnet. Mit *Ja* wird das Ergebnis bestätigt. Mit *Nein* können Sie die Parameter und den Text ändern.

Hinweis

Wenn Sie das Ergebnis mit *Ja* bestätigen, können Sie keine weiteren Parameter- oder Textänderungen mehr durchführen. Vielmehr wird das Ergebnis in Designlinien umgewandelt. Diese können Sie dann individuell anpassen.

Zeichensatz

Pro Objekt können Sie nur einen Zeichensatz verwenden. Mit *<Links>* auf den Zeichensatz wählen Sie den gewünschten.

Text

Den Monogrammtext können Sie in das vorgesehene Feld eingeben. Sie können aber auch bei der Ersteingabe den Text auf die Konturlinie schreiben. Ein *[Return]* schließt die Eingabe in diesem Fall ab. Die Korrektur erfolgt aber in jedem Fall in dem Eingabefeld. Klicken Sie hierzu an die entsprechende Stelle im Text im Eingabefeld und editieren Sie die fehlerhaften Zeichen.

Allgemeine Parameter

Schrifthöhe



Hier stellen Sie die Schrifthöhe für dieses Objekt ein. Beachten Sie, daß es sich bei diesem Parameter um die Grundhöhe des Textes handelt. Alle Buchstaben werden im gleichen Maßstab vergrößert bzw. verkleinert.

Schriftbreite



Ein Zeichen wird bei 0% proportional richtig zur Höhe berechnet. Bei einem Wert kleiner 0 werden die Zeichen schmaler, bei größer 0 werden die Zeichen breiter. Entsprechend der Änderung werden die Abstände zwischen den Zeichen angepaßt. Die Anpassung erfolgt nur bei der Verteilungsart *Automatische Aufteilung*.

Abstand



Hier können Sie den Zeichenabstand manipulieren. Durch eine positive Zahl vergrößern Sie den

Abstand. Eine negative Zahl hat zur Folge, daß die Zeichen näher zusammen rücken. Entsprechend der Änderung wird die Breite der Zeichen angepaßt. Die Anpassung erfolgt nur bei der Verteilungsart *Automatische Aufteilung*.

Aufteilungsparameter

Auf einer Kontur verteilen



Der Schriftzug wird auf einer Kontur verteilt. Diese erstellen Sie mit der *Konturbildung*. Ist diese Funktion ausgeschaltet, schreiben Sie auf einer waagerechten Linie von links nach rechts ausgehend vom letzten Stich. [Return] schließt die Eingabe ab. Es steht Ihnen nur *Linksbündig* zur Verfügung.

Linksbündig



Der Schriftzug wird linksbündig auf der Aufteilungskontur geschrieben.

Rechtsbündig



Der Schriftzug wird rechtsbündig auf der Aufteilungskontur geschrieben.

Zentriert



Der Schriftzug wird zentriert auf der Aufteilungskontur geschrieben.

Automatische Aufteilung



Der Schriftzug wird so auf die Kontur geschrieben, daß er die gesamte Länge der Kontur ausnutzt. Der Zeichenabstand wird dazu gleichmäßig angepaßt. Die Anpassung erfolgt auch, wenn Breite bzw. Abstand bei einzelnen Zeichen verändert werden.

Parameter Wickellinie

Hauptlinie

Die Hauptlinie geben Sie mit der *Konturbildung* ein.

Nebenlinie

Nebenlinien geben Sie ebenfalls mit der *Konturbildung* ein.

Der Anschlußpunkt einer Nebenlinie wird automatisch gesucht und mit einem grünen Punkt markiert.

Parametersatz



Mit [F8] PS geben Sie nach der Eingabe einer Linie (Haupt - oder Nebenlinie) den gewünschten Parametersatz ein. (Parametersatz).

General parameters

Color parameters

Color parameters

Object



This enables you to determine the color of the object. The stäffel legs of pull effects, the grid for fillings and the bored holes are created in this color.

Stitches



This enables you to determine the color of the stitches calculated for an object.

Edge



This enables you to determine the color of the edge. The edges of the bohrstäffel and zugstäffel are created in this color.

Underlay



This enables you to determine the color of the underlays calculated for an object.

Filling



This enables you to determine the color of the filling elements of an object.

Boring point/center



This enables you to determine the color of the boring points or center points of an object.

Block

Blocks are parts of a design. Within a design you can form temporary blocks, which can then be

edited, deleted or stored. Stored blocks can be loaded to a design and edited.

Block management

99 directories are available, each containing 99 locations for blocks.

The block directory can be depicted in two different ways:



Text view



Pictogram view

Click the relevant icon to switch between the display types.

Text view

Directory.Name

You can address a block by way of a number combination; the number designating the directory is separated by a dot from the number designating the block. To address the third block in the second directory, for example, enter *2.3*.

Directory name

This is where you can name a directory. First select the relevant line in the text directory list by clicking *<Left>* on the number. Enter the name in the box and activate the input with *Accept*; the new name appears in the column headed *Directory name*.

Delete directory

This function enables you to delete an entire directory from the block directory. First select the relevant line in the text directory list by clicking *<Left>* on the number. Press *Delete* and confirm the safety inquiry to delete the directory.

CAUTION

If the directory is not empty, the blocks it contains will be irrevocably deleted as well.

Delete marked blocks

This function enables you to delete marked blocks from the block directory. First select the blocks you wish to delete in the pictogram view of the block directory; switch to the pictogram view and select the blocks with *<Left>*. To deselect a block, select it a second time. Once you have selected the blocks, switch back to the text view of the block directory. Press *Delete* and confirm the safety inquiry to delete the blocks.

CAUTION

The blocks are deleted irrevocably.

Pictogram view



This function switches from the text to the pictogram view.

Pictogram view

Directory name

The directory name is shown in the header of the window in square brackets.

Dir. No.

Indicates the number of the directory.

Block No.

Indicates the block that was most recently selected.

Text view



This function switches from the pictogram to the text view.

Load block – Save block

99 directories are available, each containing 99 locations for blocks.

The block directory can be depicted in two different ways:



Text view



Pictogram view

Click the relevant icon to switch between the display types.

Text view

Directory.Name

You can address a block by way of a number combination; the number designating the directory is separated by a dot from the number designating the block. To address the third block in the second directory, for example, enter *2.3*.

Block directory 1

Block directory 1 has some special features:

When loading or saving a block in directory 1, you do not need to state the directory number each time; simply enter the number of the block from 1 to 9.

The most recently formed block is always saved in directory 1/block 1 (*1.1*).

Block name (only with "Save block")

You can state the name of the block here.

Directory name

This is where you can name a directory. First select the relevant line in the text directory list by clicking *<Left>* on the number. Enter the name in the box and activate the input with *Accept*; the new name appears in the column headed *Directory name*.

Pictogram view



This function switches from the text to the pictogram view.

Pictogram view

Directory name

The directory name is shown in the header of the window in square brackets.

Dir. No.

Indicates the number of the directory.

Block No.

Indicates the block that was most recently selected.

Text view



This function switches from the pictogram to the text view.

Select block

Select a block by clicking `<Left>` on the relevant field. A selected box is indicated by a footer in the form of a pressed button.

General directory

General description

The general directory enables you to manage the portfolio of designs. It contains the designs' key data, such as the design number, name etc..

The directory offers you designs to select for further processing. Depending on the manner in which it is called, the content of the directory may be filtered before it is displayed. If you have to select an image, the directory presents only designs that contain images.

For each manner of calling, the EPCwin system memorizes the most recently selected design and places the cursor on it the next time the same option is used; you can then select the design immediately by pressing `[Return]`.

If the standard installation procedure is followed, the name of the main directory is EPCwinData. You can create several design sub-directories within the main directory.

Example:

```
EPCwinData
  DesignData 1
  DesignData 2
  ...
```

Each sub-directory contains a general directory. Each general directory can contain up to 10,000 designs.

The general directory can be displayed in two different ways:



General directory – Text view



General directory – Pictogram view

The EPCwin system memorizes the most recent form of display and selects it the next time the directory is called.

General directory – Text view

General information is contained under [General directory](#).

Structure and meaning of text rows

Design number	Design name	Group	Customer	Stitches	Date	Time	C	IDP	Mh/S
00-010-000.00	Kleine Bluete	Blumen	Maier	19200	25.04.2000	14:32	5	101	Mh or S

Design number	Unique design identification number
Design name	Name of the design
Group	Group assignment
Customer	Customer assignment
Stitches	Number of stitches in the design
Date	Date most recently saved
Time	Time most recently saved
C	Number of colors (needles)
IDP	Elements belonging to the design: Image Drawing data Punch data
Mh/S	Indication of design type: Mh = multi-head; S = schiffli

If you select a schiffli design in the multi-head work mode, the system asks whether you wish to convert it from schiffli to multi-head. [Convert design](#)

Functions in the text directory:



The text directory offers numerous functions for marking and sorting as well as for displaying information. You can mark several designs at once according to the principles that customarily apply with WINDOWS, by using the [\[Shift\]](#) key for a series of consecutive designs or the [\[Strg\]](#) key for a series of distributed designs.

Selecting the design directory



Three options are available for specifying the active design directory:

- Browse the computer directory structure (including network).
- Home: selects the home directory that was set under Data directories / Default setting.
- Favorites: selects from the directories you have used in the past.

Browse

[...]

Searches the computer directory structure for an EPCwin data directory. The selected directory must have been created by the EPCwin system and contain a file called [DesignDirectory](#).

Home



This function elects the home directory defined with **Default setting** as the current directory.

Favorites

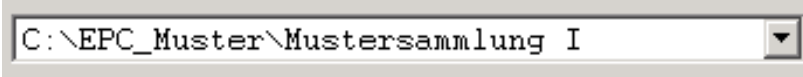

Each data directory you select is documented by the EPCwin system. This enables you to select the desired data directory from the ones you have used in the past.

The EPCwin system manages up to 50 entries. To remove specific entries from the list of favorites, activate the *Delete entry* option and select the data directory you wish to eliminate.

Write protection



A pictogram notifies you if you are not entitled to write in the selected directory.

Filter



Not supported at present.

Design head



Pressing this button displays the design head of the design that is currently marked.

Pictogram view



This function switches the display from text to the **Pictogram view**. The designs that were marked remain marked.

Printing



This function enables you to print the selected rows.

Search



Activate this function to start the search once you have entered the search text in the box alongside. This is a full text search routine, so that it finds the string if it is contained anywhere within the directory row. The system marks the first directory row it finds. Each further click on the search button finds the next entry. The search automatically resumes at the beginning of the directory when it reaches the end.

Sort

Design Number	Design name
---------------	-------------

Clicking on the column header sorts the entire directory alphabetically according to the entries in that column. Clicking the same header again triggers sorting in reverse alphabetical order.

Delete



To eliminate one or more designs, activate the option *Delete design*. In the on-screen dialog that follows you can elect to delete the image, drawing, punch data, or the whole design (All). A visual check is provided by the paper basket (recycle bin) that appears alongside the option box.

Mark the designs you wish to delete and confirm by pressing the OK button. For safety reasons, you are asked to verify that you really wish to delete the selected designs.

CAUTION
The designs are eliminated irrevocably.

Current pictogram



A pictogram representing the currently selected entry is displayed at the top right.

Show info

Activating this function displays how many designs are marked and the associated storage capacity requirement.

General directory – Pictogram view

General information is contained under [General directory](#).

Functions in the pictogram directory

With pictogram view, the designs are displayed in 4 columns of 4 rows each. Each pictogram has a button with 3 pieces of information underneath:

Design number

Image/drawing/punch data

Number of stitches

If the design is marked, the representation of the button shows that it is pressed.

Information on the total number of designs and the currently marked design appears on the right of the on-screen dialog (first design always at top left). To select the active design, press [\[Return\]](#).

Text view



This function switches the display from the pictogram to the **Text view**. The designs that were marked remain marked.

Convert design

If you select a schiffli design from the general directory in the multi-head work mode, it is converted. Before the design is converted, you have to indicate from which needle in the repeat design and how many needles to the left and right of it.

The design is automatically repeated with each repeat design change. If you wish to interrupt the repetition elsewhere as well, edit markers into the schiffli design first. Each marker triggers a repetition.

Input / Output

The Input / Output menu item enables you to output data from and read data to the EPCwin system. The options include output to disk and other import / export facilities, both locally on a PC and via a network.

The following input/output options are available:

Medium



Disk: Input and output of stitch data on a 3 1/2" disk.



Transfer EPCunix data: Transfer of EPCunix data to the EPCwin system via a network.



Copy EPCwin data: Input and output of EPCwin design data.



General path: Input and output of images, vector data and stitch data.



Backup: Backup of system parameters and settings.



Export design info: Output design data as a text or image file.

Disk

The standard transport medium for stitch data is the disk. The EPCwin system is compatible with various data and disk formats for input and output purposes.

Outputting and reading in stitch data: typical applications

Output of stitch data to disk



Insert a stitch data disk. (The disk must be formatted in compliance with the desired format.)

Select the desired data format (e.g. ZSK alt ; ZSK_TC ..).

Select the desired disk format (e.g. ZSK ; DOS ..).

Select *Write*.

Select the design that is to be output in the EPCwin directory that appears, and confirm the action with *OK*.

Check the setup for the data output and make any changes that are required in the on-screen dialog *Response at function*.

Initiate the output routine with *OK*.

Reading in stitch data from disk



Insert the source stitch data disk.

Select the desired data format (e.g. ZSK alt ; ZSK_TC etc.) .

Select a disk format corresponding to the inserted disk (e.g. ZSK ; DOS etc.)

Select *Read*.

The EPCwin system displays a list of the data contained on the disk.

Select the desired design and confirm with *Read*.

Upon completion of the reading routine, the design head appears for you to edit the entries as necessary.

When you confirm the design head with *OK*, the design is transferred to the EPCwin directory.

Functional description

Determine format



If you are unsure of the format of an inserted disk, you can initiate a check by clicking on *Determine format*. Once the disk format has been ascertained, the options for stitch data and disk format on the left of the on-screen dialog automatically switch to the appropriate setting.

Caution

The routine may not always recognize the correct format because some disk formats have an ambiguous code.

Content



This function enables you to view the content of a disk. In addition to the design data, you can also see how much of the disk's capacity is free.

Read



Reads in design stitch data from disk.

Write



Writes design stitch data to disk.

Delete



Deletes design stitch data from disk.

Copy



Copies disks; the entire content of a source disk is copied to a destination disk.

Format disk



Formats disks; the format is created according to the options selected under "Stitch data / disk format".

Format DD XP



Formats DD disks under Windows XP; the format is created according to the options selected under "Stitch data / disk format".

Response at functions

The next dialog allows you to specify the response in conjunction with functions. These settings only affect the output stitch data and have no influence on the data in the EPCwin System. The following settings are available:

STOP instead of needle change

Select this function to generate a STOP code instead of a needle change code.

Trimming allowed

You can specify whether you wish a thread trimming code to be generated. A thread trimming code is issued before each needle change.

Suppress trimming up to length 1/10 mm

Thread trimming functions are output provided that the distance to the next insertion point is not less than the specified distance.

This function is not active unless *Thread trimming allowed* is selected. If you wish all the thread trimming functions to be output, select *Thread trimming allowed* and set the length to 0.

No. of needles in code

This entry specifies the maximum number of needles for coding purposes. A STOP function is generated for each needle change to a needle with a higher number (also see needle assignment).

No. of jump stitches for needle change

Mit dieser Einstellung geben Sie an, wieviele Springstiche bei einem Nadelwechsel ausgegeben werden sollen. Diese Einstellung ist nur bei Stichdatencode für Tajima und Barudan relevant.

Needle assignment

This entry determines which needle change code is to be generated for a specific needle in the data. Enter a 0 to generate a STOP code for the needle change concerned.

Caution

If you have selected the needle assignment option, remember to check the needle assignment table.

Reserve allocation

If you have selected the reserve allocation, all 10 reserve functions will be displayed together with their current number of stitches.

Click the reserve function you wish to modify. Enter the number of stitches that you wish this reserve to contain. Once you have confirmed this input, you will be shown the reserve code lines.

Click the lines you wish to modify.

Remember that each code comprises three lines: one synchronization line and two lines for the path information (x/y paths). You can edit only the synchronization line, not the path data. The path is always 0/0. Only the synchronization line is depicted on the screen. Each synchronization line contains one or two synchronization holes that cannot be edited. Holes for the signs of the x and y path contained in this line cannot be edited either. In the case of Tajima, the synchronization line also contains stitch values that cannot be edited. Certain holes, therefore, those denoted 'o', always have to be present; others, denoted 'x', depend on the path data; and the rest, denoted 'f', are freely definable (ZSK 'oxxfffff', Tajima 'fxxxxoo', Barudan 'oxxfffff').

The editing program ignores the inputs for the defined holes and sets them accordingly with the output.

A special function can comprise a maximum of 10 stitches or synchronization lines. Holes are marked with :o:, :O: or :0:. All other inputs are interpreted as 'no hole'.

Caution

**Use the reserve allocation only if you wish to generate a function in a foreign code that the EPC system does not support.
You must have sufficient knowledge of the hole code.**

Transfer EPCunix data

Transfer EPCunix data is a function for transferring, via a network, design data and pool data (images, vector data, plot files etc.) from a connected EPCunix system to your EPCwin system.

Receiving design data

Design data can only be received from an EPCunix system. The transfer procedure is described below step by step.

Select EPCunix source system



Select the source system (System_1 to System_9) from which you wish to transfer design data. With the EPCunix system, the system No. can be read from the system configuration.

Caution
Make certain that this system is active; EPCwin interrogates inactive systems for a long time and remains blocked while doing so.

Select data source

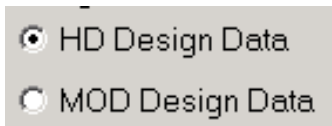

You can receive designs from the EPCunix system both direct from the hard disk and from an MO disk. If you have selected *HD Design Data*, no further action is required (continue with "Receive designs").

Load from MO disk

Since the EPCwin system cannot actively integrate the MO disk, it has to be integrated by way of the EPCunix system. The simplest method is to switch the Unix system to the status "Read design from MO disk".

With EPCunix 5.80 and above, proceed as follows:

Switch on the MO drive.

Insert the backup MO disk in the MOD drive.

Link the MO disk to the EPCunix system as follows: *Input / Output* -> *MO disk* --> *Ready* -> *Read* --> *Ready*.

The on-screen search dialog appears in the EPCunix system.

With EPCunix 5.50 and above, proceed as follows:

Switch on the MO drive.

Insert the backup MO disk in the MOD drive.

Link the MO disk to the EPCunix system as follows: *Import design* -> to the on-screen dialog *Search*.

Receive designs

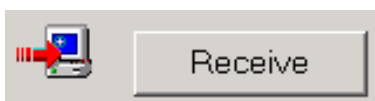

When you press *Receive*, the EPCunix directory is transferred and displayed. You can now mark the desired designs. Pressing *OK* initiates the transfer. The end of the routine is indicated by a message stating how many designs were copied.

The transferred designs are automatically integrated in the current data directory of the EPCwin system. Design numbers that do not exist in the receiving system are accepted without change; the highest unassigned number is allocated to a design whose existing number conflicts with the receiving system.

The sort buttons do not work in the EPCunix directory. In addition, the image data are not accompanied by pictograms because the data do not exist on the EPCunix system.

Receiving pool data

In the EPCunix system certain data can be saved in a pool with "Input/output -> pool". Among these

data are bitmap files (.bmp), vector data (*.dxf), text files (*.txt), plot files (*.plt), EPCunix reference data (*.epc) and stitch data in the transport code (*.zxx).

Select EPCunix source system

Select the source system (System_1 to System_9) from which you wish to transfer design data. With the EPCunix system, the system No. can be read from the system configuration.

Caution

Make certain that this system is active; EPCwin interrogates inactive systems for a long time and remains blocked while doing so.

Define local directory

Use the browse function [...] to define the local destination directory. This is the directory to which the transferred pool files are copied.

Select file type

Select the desired data type by clicking one of the options (*.bmp to *.zxx).

Receive data

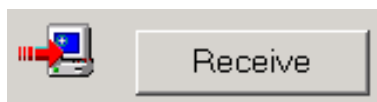

When you press *Receive*, the data available on the EPCunix system are displayed. Mark the desired data and press *Receive* to initiate the transfer.

Sending pool data

The following data types can be copied from the EPCwin system to the pool of an EPCunix system: bitmap files (.bmp), vector data (*.dxf), text files (*.txt), plot files (*.plt), EPCunix reference data (*.epc) and stitch data in the transport code (*.zxx).

Select a EPCunix destination system

Select the destination system (System_1 to System_9) to which you wish to transfer data. With the EPCunix system, the system No. can be read from the system configuration.

Caution

Make certain that this system is active; EPCwin interrogates inactive systems for a long time and remains blocked while doing so.

Select file type

Select the desired data type by clicking one of the options (*.bmp to *.zxx).

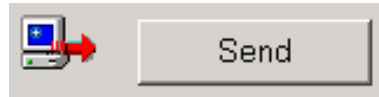
Send data

After pressing *Send*, the on-screen dialog *Select file to send* asks you to nominate the file that is to be sent. Pressing *Open* initiates the copy routine.

Copy EPCwin data

This function enables you to copy EPCwin design data from one directory to another.

The copy routine consists of two operations:

- Definition of copy parameters
- Selection of data and initiation of copy routine

Definition of copy parameters

The on-screen dialog for defining the copy parameters consists of three parts. At the top left is the field for the data source, the data destination is defined at the top right, and the parameters are shown at the bottom.

Proceed as described below to copy design data:

First select the source and destination directories**Browse**

[...]

Searches the computer directory structure (including network).

Home

This function selects the home directory defined with "System paths / Default setting".

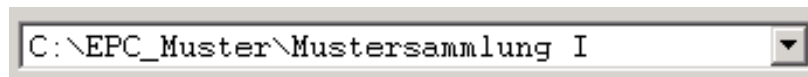
Favorites

Each data directory you select is documented by the EPCwin system. This enables you to select the desired data directory from the ones you have used in the past.

The EPCwin system manages up to 50 entries. To remove specific entries from the list of favorites, activate the *Delete entry* option and select the data directory you wish to eliminate.

View content

This function allows you to view the content of the source or destination directory, delete designs, and view the design head.

New directory



This function enables you to create a new directory.

Definition of parameters

Image



This function determines whether the image is to be copied as well as part of the copy routine.

Overwrite



This function determines whether existing designs with the same design number are to be overwritten.

Whole directory



This function determines whether the entire directory is to be copied.

Compress reading



This function determines whether the source data are to be compressed.

Compress writing



This function determines whether the data are to be written in compressed form.

As an e-mail



This function determines whether the compressed data are to be sent as an e-mail after copying. It is available only if *Compress writing* is selected.

Parameters for e-mail



Use this function to set the default parameters for e-mail. You can define the address, subject line and text specifically for the EPCwin design data output. These defaults are saved by the system.

Selecting and copying data

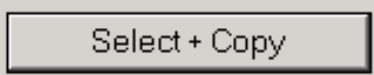

When you press *Select + Copy*, the source directory is displayed. Now mark the desired designs in the directory. Initiate the copying routine with *OK*. The designs will then be copied.

Special features when defining copy options:

Copying without compression:

The destination directory can be the same as the source directory.

The destination file must not have the extension .zip.

Make sure that the destination directory offers enough storage capacity.

A warning pictogram appears if you select a write-protected directory.

If the stated destination directory does not contain an EPCwin data structure, it is created during the copy routine.

Take special care when using the *Overwrite* option.

If directories that do not exist are selected from "Favorites", the action is not executed.

Copying with compression:



Depending on the parameter *Compress reading*, the source file must have the extension .zip.

Depending on the parameter *Compress writing*, the destination file must have the extension .zip.

If directories that do not exist are selected from "Favorites", the action is not executed.

When a .zip file is read in, the design data are initially depicted in a buffer directory in which you can select the desired data. Thereafter initiate the transfer with *OK*.

Copying with dispatch by e-mail:



If you wish to send the data as an e-mail file, it is essential that the data are compressed. The data are automatically compressed after the copy routine. Your standard e-mail program then opens with the defaulted data, including the address, subject and text. The compressed data are already attached as a file.

General path

This function enables you to export and import different types of data. In contrast to the output on disk, stitch data can be written to the hard disk or sent direct to an embroidery machine via a network. Only files for DOS stitch data formats are taken into account. The file extensions of the various formats (e.g. *.DSZ) are depicted in the dialog shown below.

The dialog contains three data areas:

- Images and vector data
- Stitch data
- Unix reference data from disk and pool

Data output

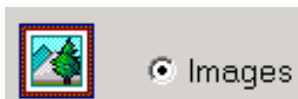

On the left select the data type, e.g. images, vector data (DXF) or stitch data, with <Left> on the relevant option.

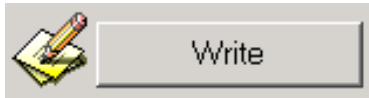

Write

When you press *Write*, the current EPCwin directory is displayed. Mark the design you wish to output and press *OK* to conform the output routine.

In the dialog that follows, enter the destination directory and conclude the output with *Save*.

Reading in data

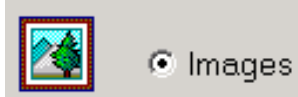

 Images

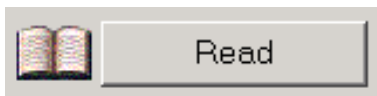
On the left select the data type, e.g. images, vector data (DXF,CMX) or stitch data, with <Left> on the relevant option.

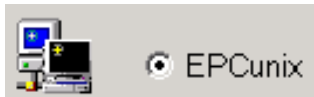

Read

After pressing *Read*, select the source file and confirm with *Open*. At the end of the read operation the design head dialog appears so that you can make final changes before final storage.

 EPCunix

To read Unix reference data from an R-DOS disk or hard disk:

Select the file on the disk ((D1 to Dnn) and (rdat_XXXXXXXX_xx.epc)) and confirm with *Open*. The reference data are decompressed and copied to the general directory.

Vector data (CMX)

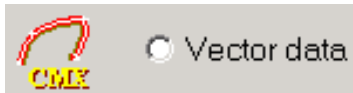
 Vector data

This function enables you to read in vector data in the Corel Presentation Exchange Format Version 6/7 (CMX).

Reading drawing data in CMX format

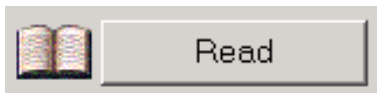

Read

After pressing *Read*, select the source file and confirm with *Open*. At the end of the read operation the design head dialog appears so that you can make final changes before final storage.

When CMX data are read in, they are converted to the EPCwin vector format. When the vector data are converted, only the graphic effects that are supported by the EPCwin system are accepted. (Filling colors, line effects etc. are filtered out.)

Only vector data can be read in by way of the CMX format. To ascertain whether the graphic is a vector graphic, select *View* and then *Outline* in Corel Draw.

If the graphic is a vector graphic, the outlines are shown. If the bitmap remains on the screen, the graphic is not a vector graphic and it cannot be read in by way of the CMX format.

Observe the following to ensure successful conversion:

After completing the drawing in Corel Draw, choose *Select all* under "Edit" and then perform *Cancel*

combination and *Cancel object grouping* under "Arrange" provided that these functions are active. If they are not, these two menu items are shown gray.

If they are not, these two menu items are shown gray. Depending on the attributes of the graphic objects, it may be advisable to merge them in order to obtain a common outline for several intersecting objects.

To do so, select *View* and then *Merge*.

To output data in the CMX format, select *Export* under *File* in Corel Draw and, under *File type* in the file selection box, *Corel Presentation Exchange 6/7(CMX)* in order to set the correct format.

Vector data (DXF)



This function enables you to read in vector data in the AutoCAD format (DXF) and to write EPCwin drawing data in the AutoCAD format (DXF).

Writing drawing data in DXF format

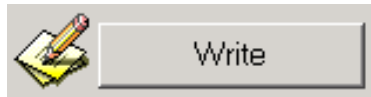

When you press *Write*, the current EPCwin directory is displayed. Mark the design you wish to output and press *OK* to conform the output routine.

In the dialog that follows, enter the destination file and conclude the output by clicking the *Save* button.

Reading drawing data in DXF format

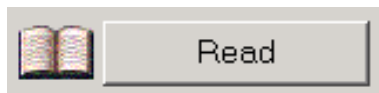

After pressing *Read*, select the source file and confirm with *Open*. At the end of the read operation the design head dialog appears so that you can make final changes before final storage.

When DXF data are read in, they are converted to the EPCwin vector format. When the vector data are converted, only the graphic effects that are supported by the EPCwin system are accepted. (Filling colors, line effects etc. are filtered out.)

Only vector data can be read in by way of the DXF format. Bitmaps (images) cannot be read in. To ascertain whether the graphic is a vector graphic, select *View* and then *Outline* in Corel Draw. If the graphic is a vector graphic, the outlines are shown. If the bitmap remains on the screen, the graphic is not a vector graphic and it cannot be read in by way of the DXF format.

Observe the following to ensure successful conversion:

After completing the drawing in Corel Draw, choose *Select all* under "Edit" and then perform *Cancel combination* and *Cancel object grouping* under "Arrange" provided that these functions are active.

If they are not, these two menu items are shown gray. Depending on the attributes of the graphic objects, it may be advisable to merge them in order to obtain a common outline for several intersecting objects.

To do so, select *View* and then *Merge*.

To output data in the DXF format, select *Export* under *File* in Corel Draw and, under *File type* in the file selection box, *AutoCAD (DXF)* in order to set the correct format.

Backup

Data

Use a proprietary backup tool to make a backup of your design, block and monogram data. Such tools allow you to save and reload data according to individual criteria. As a general rule they can also be configured to execute a backup routine automatically, typically every day.

Saving design data (backup)

The design data are generally stored in the directory named *EPCwinData/DesignData*, but you may have created your own design data directories. To make a backup of the design data, you must save the entire content of the relevant directory.

Saving block data (backup)

The block data are generally stored in the directory named *EPCwinData/BlockData*, but you may have created your own block data directories. To make a backup of the block data, you must save the entire content of the relevant directory.

Saving monogram data (backup)

The monogram data are generally stored in the directories named *EPCwinData/MonogrammDataPunch* and *EPCwinData\GiSFonts*, but you may have created your own monogram data directories. To make a backup of the monogram data, you must save the entire content of the relevant directory.

Parameters

The backup function for parameters enables you to save and reload EPCwin system parameters as well as settings.

Caution

The file designations (e.g. head_001) must not be altered.

Saving parameters and settings

Create destination directory



First, using the Explorer, create a directory in which to save the data.

Select destination path /Browse

[...]

Searches the computer directory structure (including network) and selects the directory as the destination directory.

Select destination path / Favorites

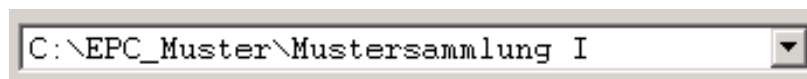

Each data directory you select is documented by the EPCwin system. This enables you to select the desired data directory from the ones you have used in the past.

The EPCwin system manages up to 50 entries. To remove specific entries from the list of favorites, activate the *Delete entry* option and select the data directory you wish to eliminate.

Select parameters and settings

Select the items you wish to save. To select all the options, press [Select all](#).

Write

Writes the parameters and settings to the destination directory. The name of the subdirectory that is automatically created contains the date.

Check content

This function displays the content of the destination directory.

Loading parameters and settings**Select destination path /Browse**

[...]

Searches the computer directory structure (including network) and selects the directory as the destination directory.

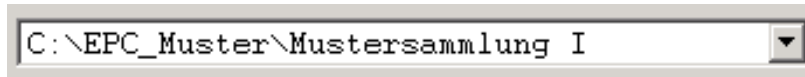
Select destination path / Favorites

Each data directory you select is documented by the EPCwin system. This enables you to select the desired data directory from the ones you have used in the past.

The EPCwin system manages up to 50 entries. To remove specific entries from the list of favorites, activate the [Delete entry](#) option and select the data directory you wish to eliminate.

Select

Select the items you wish to reload. To select all the options, press [Select all](#).

Read

Reads the parameters and settings from the source directory to the EPCwin files.

Export design info

This function enables you to output specific information concerning individual designs or a formatted directory if, for example, you wish to read the directory to a database or spreadsheet program. You can also output designs as an image file in the size and view of your choice.

Three options are available:

1. Output of design head and statistical information
2. Output of marked directory rows
3. Output of design as image file

Select destination path /Browse

[...]

Searches the computer directory structure (including network) and selects the directory as the destination directory.

Select destination path / Favorites

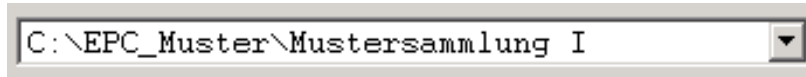

Each data directory you select is documented by the EPCwin system. This enables you to select the desired data directory from the ones you have used in the past.

The EPCwin system manages up to 50 entries. To remove specific entries from the list of favorites, activate the *Delete entry* option and select the data directory you wish to eliminate.

Create new directory



This function enables you to create a new directory.

Define separating character



Definition of the column separator, e.g. [#]. This is the character used to separate the individual information fields.

View destination directory



This function displays the content of the destination directory.

Output of design head and statistical information



Activate this function if you wish to export information concerning individual or several designs. The design data are saved row by row in a file in the destination directory. The individual fields (columns) are output separately with the aid of the separating character.

To specify which parts of the design head you wish to output, choose *Settings*; click the relevant fields in the on-screen dialog that follows. Confirm the selection with *OK*.

Initiate output



This function triggers the output. Select the desired designs in the directory and confirm the selection with *OK*.

The design information is output to a file called *DesignInfo_1* in the stated directory. If a file with this name already exists, the number that forms part of the name is incremented.

Output of marked directory rows



Activate this function if you wish to export one or several rows of a directory. The rows are saved in a file in the destination directory. The individual fields (columns) are output separately with the aid of the separating character as defined above.

Initiate output



This function triggers the output. Select the desired designs in the directory and confirm the selection with *OK*.

The design information is output to a file called *DirectoryOut_1* in the stated directory. If a file with this name already exists, the number that forms part of the name is incremented.

Output of design as image file



Activate this function if you wish to export an individual or several designs as an image file in .bmp format. You can specify the output file size from 100 to 1200 pixels.

Influencing output with view function



You can define how the output is depicted with *View*. You can, for example, output designs to look like the embroidered work (embroidery view) and you can mask individual needles.

Initiate output



This function triggers the output. Select the desired designs in the directory and confirm the selection with *OK*.

The designs are saved in the destination directory as a bitmap file designated with the design number.

Scanner



Press button <Left> on the scanner symbol to initiate the scanning operation. A list of image reading devices (scanners, cameras) appears on the screen. Select one of the options (e.g. with *Select*). This dialog and the ensuing scan program do not form part of the EPCwin software. Follow the instructions for the scan program; it should contain a button with a label similar to *Transfer to application*.

Among other things, the delivery scope of the scanning software must contain a Twain driver.

Instead of a scanner, you can use a digital camera provided that it can be addressed by a Twain driver. The same applies to any image capture device.

If a security box is connected to the parallel port and you wish to connect a scanner with a parallel interface (possibly as well as a printer with a parallel connector), you are recommended to install a second parallel port. Connect the security box to one of the parallel ports and the printer and scanner

to the other one.

Imaging

Imaging enables you subsequently to process an imported or scanned image.

The options include modifying the brightness, contrast, size and color, as well as rotating and mirroring, and cutting out a section of the existing image.

In addition, two separate images can be linked.

Starting imaging



Pressing <Left> on the symbol initiates the imaging process.

Link

Select **Link** to join two images.

Action

Action processes the image by modifying the settings for brightness, contrast and size. The result is a new starting image. The previous settings are invalidated.

Load image

Pressing *Load image* opens the directory so that you can select an existing image. A temporary copy is made as the basis for the subsequent processing stages.

Restore image

Reset image reloads the original image. As with *Load image*, the system initially generates a temporary copy. This operation scraps the image that was being processed.

Save

Use *Save* to save the processed and modified image as a new image in the directory.

Cancel

Cancel interrupts imaging without saving; the current image is scrapped.

Brightness and contrast



Moving the brightness slide control adjusts the brightness factor of the image on the screen. The same principle applies to the slide control for contrast.

Size



You can specify the width and height of the image as a percentage. The original size is 100%, so that lower values reduce, and higher values enlarge the image. Selecting the *Proportional* option has the effect of modifying both the width and the height; in other words, the percentage values are the same.

Full size display



The *Full size display* switch does not execute any direct action, but alters the size of the image in proportion to the working window. This overrides the percentage values for the height and width.

Cut out



Cut out enables you to trace a rectangle and thus select a portion of an existing image. Click <Left> twice to create a rectangle; the two points represent diagonally opposite corners of the rectangle. Provided that you have not defined the second point, you can abort the operation with [Esc]. You can zoom with [Page up] and [Page down]. The section you cut out of the image forms the new starting image. You can place the two points outside of the existing image if you wish. In this case, the edge of the image is formed by the limit of the current display.

Mirror and rotate



The buttons *Mirror horizontal*, *Mirror vertical*, *90°* rotation, *180°* rotation and *270°* rotation immediately execute the rotate or mirror operation. The result is a new starting image.



Rotate enables you to define a new vertical or horizontal axis. This operation is useful, for example, if an image was not scanned in perpendicular. To operate the function, click <Left> on a horizontal or vertical line contained in the image, then again somewhere else on the same line. Pressing [Esc] aborts this operation.

Color



Change color enables you to substitute one or several colors contained in the starting image with any other color. To do so, mark a picture element; the on-screen dialog that appears invites you to select the substitute color. The result is a new starting image. You can mark several picture elements at once by holding down [Strg] while marking. Confirm the selected lot with [Return]. The value entered in the box *Length of the changing square* indicates how many adjacent picture elements in a square around the one that is marked are to have their color changed. Pressing [Esc] aborts this operation.

Link

You can link (join) two images by loading them both and defining a joining edge (horizontal or vertical). Initiate the function by clicking with <Left> on *Link* in the imaging dialog. The on-screen dialog that then appears enables you to determine the orientation of the join for the first image that is loaded.



Top and bottom orientation have the effect of joining the two images horizontally, and left and right orientation links the images vertically.

The source for the first image is either the directory (*Load image*) or the most recently linked image (*Load temporary image*). The source for the second image can only be the directory.

Once you have selected and loaded the two images, they are aligned as specified: either the bottom left of the top image interfaces with the top left of the bottom image, or the top right of the left image interfaces with the top left of the right image.

The green bar in the left or bottom margin indicates the image to which the desired actions refer.

Link images

Pressing [Return] executes the link. The dialog that then appears enables you to link the new image with a further image (*Continue linking*) or to save the new image in the directory (*Save and exit*). If you wish to continue linking, you can stipulate the destination (top, bottom, right, left) of the further image that is being linked.

Shift image

Use the cursor keys to displace the reference image by one picture element to the left or right, or upwards or downwards. Pressing [Strg] at the same time displaces the image by 10 picture elements. The displacement is executed relative to the other image.

Zoom

Pressing [Page up] and [Page down] changes the zoom factor incrementally.

Link point



Press <Left> to fix the point in each image at which the interface for the join is to be formed depending on the orientation (horizontal or vertical).

Pressing [F9] executes and displays the link.

Interface



Pressing [F2] switches the orientation of the interface from horizontal to vertical and vice versa.

Swap images



Pressing [F3] interchanges the images; in other words, the image on the left becomes the image on the right, or the top image becomes the bottom image.

Reference image (focus)



Pressing [F4] defines the reference image on which the operations (e.g. rotating) are to be executed. The position of the green bar changes accordingly.

Rotate image



Pressing [F5] rotates the image through 90 degrees (counter-clockwise), and pressing [F6] rotates it through 270 degrees (90 degrees clockwise).

Image axis



[F7] enables you to define a new vertical or horizontal axis. This operation is useful, for example, if an image was not scanned in perpendicular. To operate the function, click <Left> on a horizontal or vertical line contained in the image, then again somewhere else on the same line. Pressing [Esc] aborts this operation.

Restore image



Pressing [F8] reloads the starting image. This function reverses the operations (e.g. rotating) performed on the image.

Printing

The print dialog allows you to print the active design.

Define print area



Use this function to define the area to be printed by tracing a rectangle with two clicks on <Left>. If you do not define a print area, the entire design is printed.

View



This function calls the dialog for the **View**. The settings made here apply to the printout.

Reset



This function reverts to the most recently saved settings for *Parts* and *Format settings*.

Parts

The options described below determine which elements are to be printed. Pressing *Printing* initiates the printout. Depending on the compilation of options, the printout can consist of several pages.

Design



When this option is set, the design is printed according to the settings in "View".

Design head:



When this option is set, the design head is printed.

Embr. heads



When this option is set, the design head symbol is printed.

Background



When this option is set, the background is printed.

Needle colors



When this option is set, the needle colors used in the design are printed.

Needle designs



If this function is selected with a schiffli design, the needle designs used in the design are printed as well on separate sheets.

Format settings

Full size display



When this option is set, the size of the design is adjusted to fit the page.

Start/end (large)



When this option is set, the symbols for the design start and end are printed large.

Start/end (small)



When this option is set, the symbols for the design start and end are printed small.

Scale



Here you can enter a scaling factor.

Width



Here you can enter the margin width in mm.

Line thickness



Here you can enter line thickness 1, 2 or 3. The thinnest line is 1. If you enter a value outside the range, the line thickness is set to 3.

Headline



Here you can enter a text to appear as a header on the printout.

Utilities

The individual menu items under "Utilities" are used to make system settings, release passwords and implement checks.



Entering passwords



Default settings



Check directory



Create block directory



Default settings

The on-screen dialog *Default settings* enables you to define all the settings required for working with the EPCwin system.

The default settings cover the subjects indicated below. Select the desired subject by clicking the relevant tab; the page for the settings appears.

Press *Accept* to confirm and accept the settings made in an individual tab dialog.

Pressing *OK* accepts the confirmed settings adopted on the individual tabs and closes the dialog. Press *Cancel* to close the dialog without accepting the settings.

The following tabs are available:

General

Depiction

Editor

Selection

Communication

Data directories

System paths

Language

Administration

Work mode

General / Default setting

Work procedure

View default setting



Here you define the *View* that applies when a design is opened.

Screen factor



The screen factor ensures that a design is depicted accurately on the screen according to the set dimension system. To set the factor, draw a 15 cm square in a design and set the zoom factor to 1. Measure the size of the square on the screen. If it measures 17 cm, for example, the screen factor is $15/17 = 0.88$. Enter this value here as the screen factor.

Zoom offset



This option determines the increments by which the design is enlarged and reduced with [Page up] and [Page down] when **Zoom** is selected.

Scrolling



Sets the scrolling speed.

Beeper



Sets the volume of the beeper.

Activate measuring system



If this option is activated, you have to define a measuring system when creating a new design with an image.

Automatic backup

Interval



State the interval in minutes between the saving routines that create design backups.

Multiple backup

If this option is activated, due regard is paid to the number of interim versions of a backed-up design. Each time the backup operation is executed, a new interim version of the design is created.

Number

Enter the number of interim versions to be backed up.

Hardware setup

Floppy drive B

If this option is activated, the floppy disk drive is designated drive B. If it is not activated, the floppy disk drive remains drive A.

Depiction / Default settings

Line width



Here you can set the line thickness that applies when drawing cords, loops and braids.

Borer size

When the "Borer on" special function is selected with (manual) punching, the appearance of the cross-hair pointer changes. A hash symbol representing the borer is drawn around the center of the pointer. You can set the size of this borer symbol here.

Borer size MH



The value you enter here defines the size of the borer symbol in 1/10 mm for the multi-head work mode.

Borer size S



The value you enter here defines the size of the borer symbol in 1/10 mm for the schiffli work mode.

Marker size drawing

Drawing lines



This option defines the size of the drawing line reference point markers as depicted on the screen.

Marker size punch

Reference data



This option defines the size of the reference data reference point markers (punch contours) as depicted on the screen.

Manual



This option defines the size of the manual stitch markers as depicted on the screen.

Object



This option defines the size of the program stitch markers as depicted on the screen.

Special function



This option defines the size of the special function markers as depicted on the screen.

Center marker size

The value you enter here defines the size of the center marker for the geometric drawing figures.

Center marker by object size

This option refers to the *Center point* function of the **Tool box**. If the option is activated, the *Center point* function gives rise to a center marker with the dimensions of the edit box. Otherwise the marker is smaller.

Editor / Default settings

Initial settings editor



Activate editor view

When this button is activated, the current view settings are retained when you switch to the editor or block function.

Selection / Punching editor

View default setting



Here you can enter the default settings for the **View** as used when you start the editor from punching or the main menu.

Gray mode



When this option is activated, the design is depicted in the dim color defined in the design head when the editor is started from punching or the main menu.

Selection / Drawing editor

View default setting



Here you can enter the default settings for the **View** as used when you start the editor from drawing.

Gray mode



When this option is activated, the design is depicted in the dim color defined in the design head when the editor is started from drawing.

Editor values

Copy offset



The value you enter here determines the spacing for copying the selected data, offset to the bottom right, in the design. The value applies to both the horizontal and the vertical direction.

Automatic calculation after reference data input

If this option is activated, calculation of the embroidery object is initiated once the reference data have been entered when punching.

Selection / Default setting

Snap radii [1/10 mm]

Point



Here you define the distance from which the cursor can select a point. The snap radius for a point should be smaller than that for a line.

Line



Here you define the distance from which the cursor can select a line.

Grid



Here you define the distance from the grid from which a point can be drawn towards the grid line.

Corner creation



Here you define whether the distance between two points is to be relatively large or small when double-clicking to create a corner.

Step size (cursor keys)

Here you define the size of the steps that are taken when you run through the design with the cursor keys. It is also the speed that applies to **Continuous selection**. Make certain that one of the values for either Left/Right or Up/Down is 1, otherwise you will not be able to move through the design one stitch at a time.

Up / Down



Step size for the up / down cursor keys.

Left / Right



Step size for the left / right cursor keys.

+ Ctrl



Enlarged step size that applies when one of the cursor keys is pressed together with [Ctrl]. The pair of cursor keys (either up / down or left / right) that is not set to 1 executes these large steps.

Communication / Default setting

E-mail setting for reference data output



Here you define the defaults for sending reference data by e-mail. Settings can be defined for the e-mail address, subject and a standard text

E-mail setting for stitch data output



Here you define the defaults for sending stitch data by e-mail. Settings can be defined for the e-mail address, subject and a standard text

E-mail setting for system check



Here you define the defaults for sending the result of the system check by e-mail. Settings can be defined for the e-mail address, subject and a standard text

Data directories / Default setting

Change home directory for

Design



Here you can select the current home directory for designs with the relevant button "...". Use of this function makes sense only if you have created several design directories. The home directory is activated, for example, when you click on the icon depicted below in [General directory](#).



Block data

Here you can select the current home directory for blocks with the relevant button "...".

Monograms

Here you can select the current home directory for monograms with the relevant button "...".

TT monograms

Here you can select the current home directory for True-Type monograms with the relevant button "...".

Create new data structure (total)**Last directory**

This function enables you to create an entire data structure for design, block and monogram data. Click on *Create new structure in* to select the folder that is one step higher in the hierarchy, so that the new data structure is created in that folder. If you select the folder `Design_Year_2000`, you obtain the following structure:

Design_Year_2000

- |- DesignData
- |- BlockData
- |- IOData
- |- MonogrammDataDrawing
- |- MonogrammDataPunch

New directory

Use this function to create a new directory.

System paths / Default setting**Define system paths****Temp path**

Here you define the path for temporary files with the "..." button if, for example, the Temp subdirectory of the EPCwin directory that is created automatically during installation is located on a hard disk with insufficient capacity. Various temporary files are saved in this directory while you are working with the

EPCwin system.

New directory



Use this function to create a new directory.

Language / Default setting

Select the desired dialog language by clicking <Left> on the appropriate country symbol.

Administration / Default setting

Error recording

The EPCwin system is capable of logging faults. You can determine the extent to which it documents faults by entering a value from 0 to 6. If you enter 0, no fault log is kept. You should not normally alter the settings. In case you encounter difficulties with the EPCwin system, a customer service engineer may ask you to change one of the values.

A distinction is made between general and calculation errors.

Calculation



Calculation errors are those that can occur, for example, during stitch calculation or verify routines.

General



General errors are those that can occur, for example, when designs are being loaded or data are being written to disk.

System and error documentation

Convert the documentation files for MS-Excel



This function processes the error data for reading to Microsoft Excel and saves them in the file [/EPCwin/EpcSystemDaten/Error/EpcErrorGlbZeile](#).

Reset documentation files



This function resets (empties) the documentation files.

No. of recorded actions

The EPCwin system documents file access operations while you are working with the system. The number of these operations and a security status are depicted here in encoded form.

Reset operations



This function resets the number of file access operations to 0.

Work mode / Default setting

Select current work mode



You can select the work mode you wish to adopt with EPCwin here.

The input boxes and buttons for the preconfigurations applicable to multi-head or schiffli embroidery are enabled or disabled accordingly.

Multi-head preconfigurations / Schiffli preconfigurations

Four different preconfigurations for the design head and parameters are available for each work mode: Here you can

- activate one of the preconfigurations
- name the preconfigurations
- call the [Design head dialog](#)
- call the [Parameter selection dialog](#)

Entering passwords

The EPCwin program cannot be used until it is enabled by entering the relevant passwords. There are three types of password.

1. Product ID
2. Standard passwords to enable program options
3. Time-limited (demo) passwords

Re 1. Product ID

When you start the EPCwin program for the first time, you are asked to enter the 12-character product ID. Once the password is accepted, the main menu appears on the screen. The program is closed automatically if an incorrect password is entered several times.

Re 2. Standard passwords

Program options are enabled under [Utilities/Password](#).

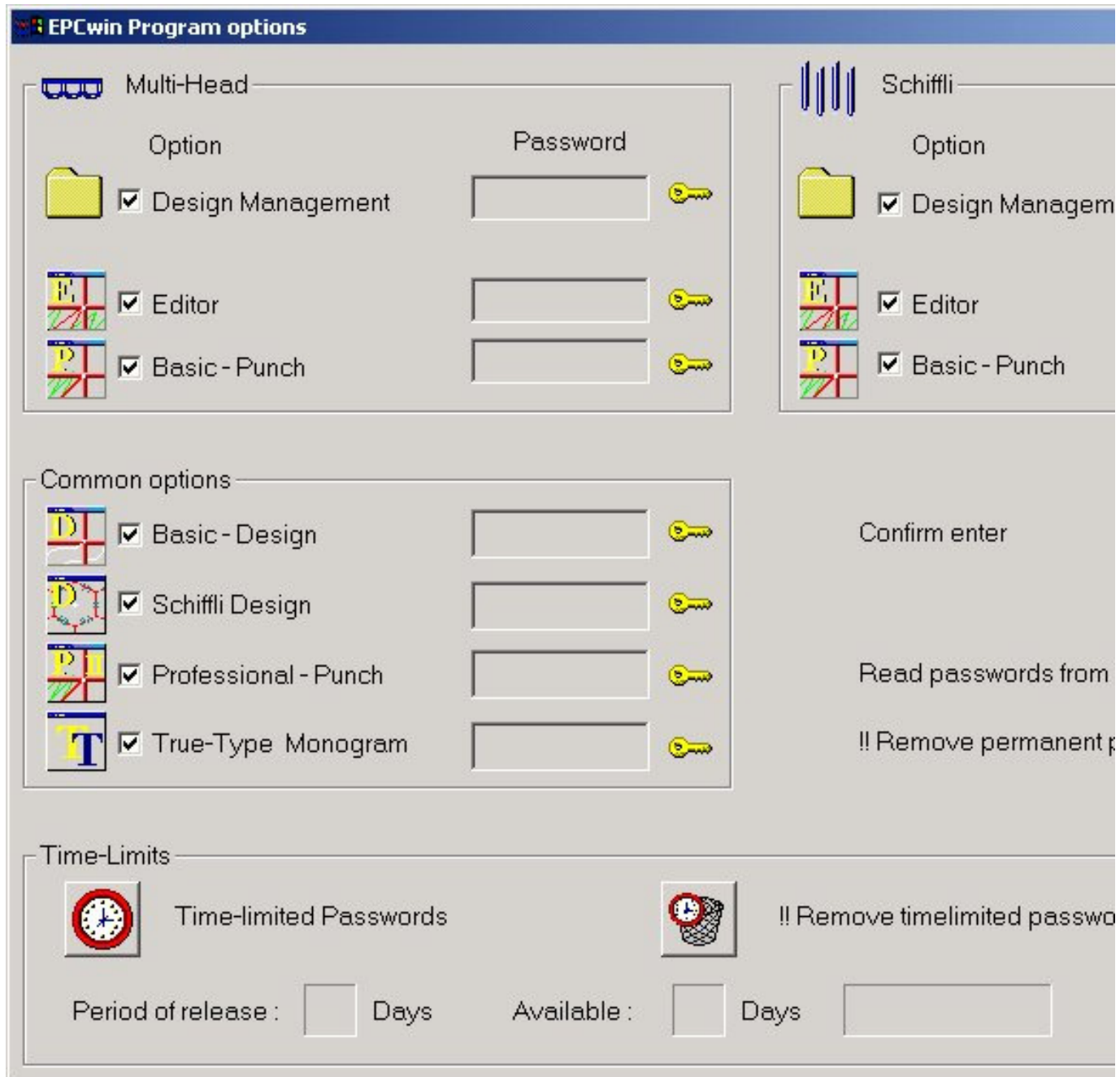

Reading in passwords from a file:

The quickest way of entering the passwords required by your EPCwin system is to read them in from a file. ZSK Support sends the file as an attachment to an e-mail. Save the file to a 3½" disk. Click <Left> on *Read in passwords from file*. EPCwin first accesses the disk drive. Select the saved password file: *EPCwinPSW*.

If you saved the file to hard disk rather than to a floppy disk, go to the storage location and select the file.

Entering manually:

Take the sheet containing your passwords. Select the *Design management* option, enter the password and activate the option with <Left> on *Confirm input*. Follow the same sequence for all the other options. Once activated, a key icon appears alongside the option.

If you enter a password incorrectly several times, the waiting time between entries increases. Once you have activated the desired options, exit the dialog with *Close*. You can now use the EPCwin program with the enabled options.

Re 3. Time-limited passwords







Program options are enabled for temporary use under *Utilities/Password/Time-limited password*. Before activating temporary options, please consult ZSK Support. This is necessary because the enabled period has to be determined in advance.







The following dialog appears on the screen:

EPCwin programm options Limited Release

No. of days  Key

Multi-Head		Schiffli	
Option	Password	Option	Password
 <input type="checkbox"/> Design Management	<input type="text"/>	 <input type="checkbox"/> Design Man	<input type="text"/>
 <input type="checkbox"/> Editor	<input type="text"/>	 <input type="checkbox"/> Editor	<input type="text"/>
 <input type="checkbox"/> Basic - Punch	<input type="text"/>	 <input type="checkbox"/> Basic - Punc	<input type="text"/>

Common options

 <input type="checkbox"/> Basic - Design	<input type="text"/>
 <input type="checkbox"/> Schiffli Design	<input type="text"/>
 <input type="checkbox"/> Professional - Punch	<input type="text"/>
 <input type="checkbox"/> True - Type Monogram	<input type="text"/>

 Release all options

Confirm ente
Read passw

Program options enabled with a time limit are always enabled for a specific number of days.

Proceed as follows:

Enter the enabled period in the box alongside *No. of days*. Click on the calculator symbol alongside. A 15-digit number code appears in the three boxes alongside. Notify ZSK Support of this code so that the passwords you need can be calculated.

Note

Do not exit this dialog before making all the necessary entries. Do not have a new number code calculated by entering another number of days because this would invalidate the passwords calculated for the first number code.

Reading in passwords from a file:

The quickest way of entering the passwords required by your EPCwin system is to read them in from a file. ZSK Support sends the file as an attachment to an e-mail. Save the file to a 3½" disk. Click <Left> on *Read in passwords from file*. EPCwin first accesses the disk drive. Select the saved password file: *EPCwinPSW*.

If you saved the file to hard disk rather than to a floppy disk, go to the storage location and select the file.

Entering individual options manually:

Once you receive the passwords, select the *Basic System* option, enter the password and activate the option with <Left> on *Confirm input*. Follow the same sequence for all the other options. Once activated, a clock icon appears alongside the option.

If you enter a password incorrectly several times, the waiting time between entries increases. Once you have activated the desired options, exit the dialog with *Close*. You can now use the EPCwin program with the enabled options.

Entering all options manually:

Once you have received the password, tick the box *Enable all options*. Enter the password in the box alongside and activate the option by clicking <Left> on *Confirm input*. Once activated, a clock icon appears alongside this option.

Check directory

The *Check directory* function operates in a design directory; it reconciles the *EPCwin general directory* with the data contained in the directory. It can also be used to create a new directory containing the existing data.

Caution

It is essential that you save your data before performing any of the routines described below.

Check directory has two functions:

- Check directory
- Create new directory

Define directory path

Selecting the design directory

Three options are available for specifying the active design directory:

- Browse the computer directory structure (including network).
- Home: selects the home directory that was set under Data directories / Default setting.
- Favorites: selects from the directories you have used in the past.

Browse

[...]

Searches the computer directory structure for an EPCwin data directory. The selected directory must have been created by the EPCwin system and contain a file called *DesignDirectory*.

Home



This function elects the home directory defined with *Default setting* as the current directory.

Favorites

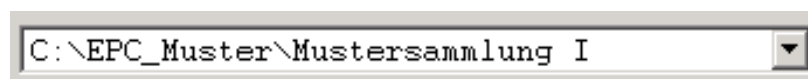

Each data directory you select is documented by the EPCwin system. This enables you to select the desired data directory from the ones you have used in the past.

The EPCwin system manages up to 50 entries. To remove specific entries from the list of favorites, activate the *Delete entry* option and select the data directory you wish to eliminate.

View directory



This function shows you the content of the data directory.

Check directory

Check directory reconciles the selected general directory with the data files that it contains. Each entry in the general directory can embrace various files. One of these must be a design head file. A design can be accompanied by image, drawing and punch data. The check routine ascertains which files exist and enters the result in the directory. If a design head does not exist, the corresponding row in the directory is deleted.

Start check

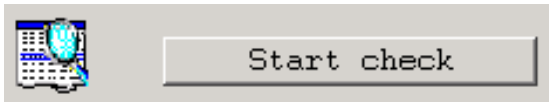

Press *Start check* to initiate the operation.

Create new directory

The function *Create new directory* starts by deleting the current general directory file. Each design head is then opened and the information that is depicted in the directory (design name and number, group etc.) is read out. A new directory row is created on the basis of this information

Start creation

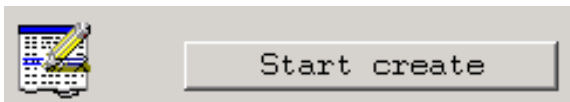

Press *Start creation* to initiate the operation that recreates the directory.

Create block directory

The purpose of *Create block directory* is to restore a lost or destroyed block directory from the surviving block data.

Caution

It is essential that you make a backup copy of the block data before executing the operation described below.

Start creation



Press *Start creation* to initiate the operation that recreates the directory.

Transfer system parameters from EPCunix to EPCwin

Follow the procedure described below to transfer the system parameters of a UNIX-based EPC system to EPCwin.

Make an FTP connection from the PC to the UNIX workstation.

Enter the login name *pcnet*. The password is *420*.

Copy the files

/users/eds/EPC_PARA/POOLS/gl_pool_001 and

/users/eds/EPC_PARA/HEADS/head_001 to directory *EPCwin/EpcSystemDaten/Temp/*

Start the EPCwin system.

Select *Utilities* and the function *Parameter Conversion*.



If no message is issued, the routine has been executed.

You can check the standard design head in *Utilities/Default Settings*.

You can check the system parameter sets, distance ramps etc. in the main menu under *Parameters*.

System check

This dialog displays information on the operating system and the EPCwin program as well as the results of various checking operations.

A green tick alongside an entry indicates that the check did not reveal any errors. A red cross indicates that errors were detected.

Mail to ZSK

Press this button to mail the information contained in the dialog and other details to ZSK.

Output to disk

Press this button to output the information contained in the dialog and other details to disk.

Print

Press this button to print the information contained in the dialog and other details.

Stichwortverzeichnis

—A—

Abfrage Suchen und Ersetzen 153
Administration / Default setting 221
Arc 161
Automatic programs 114

—B—

Backup 204
Birnenloch 98
Birnenloch parameters 179
Block 186
Block filter multi-head 130
Block filter schiffli 131
Block list 156
Block management 187
Blockfilter 130
Bohrhöhl 92
Bohrhöhl parameters 173
Bohrstäffel 88
Bohrstäffel parameters 169
Border 85
Bored hole 97
Bored hole parameters 178
Boring effects 177

—C—

Center design 44
Check design 30
Check directory 226
Circle 160
Color definition 41
Color parameters 186
Color table 42
Communication / Default setting 219
Continuous selection 129
Contour 116
Convert design 193
Copy EPCwin data 199
Create block directory 227
Cross boll 102
Cross boll parameters 183
Cross stitch grid parameters 124

—D—

Data directories / Default setting 219
Default settings 214
Depiction / Default settings 215
Design head 31
Design head multi-head 31
Design head schiffli 36
Design statistics 30
Design statistics design 31
Design statistics multi-head 30
Disk 193
Display 43

Double border 86
Double border parameters 169
Double zugstäffel 90
Double zugstäffel parameters 171
Drawing 159

—E—

Edit box 145
Edit contour 137
Edit contour point 138
Edit cross point 140
Edit drawing line 141
Edit drawing line point 142
Edit drawing object 143
Edit drawing object contour 144
Edit drawing object contour point 144
Edit end point 140
Edit manual stitches 133
Edit marker 135
Edit maximum stitch length 135
Edit object stitches 135
Edit objects 136
Edit special function 134
Edit stitch direction marker 139
Editor 125
Editor / Default settings 217
Ellipse 162
Ellipse (Angle) 162
Entering passwords 222
EPCwin directory structure 23
EPCwin system limits and variables 24
Export design info 205

—F—

Filling effects 172
First steps 11

—G—

General 10
General / Default setting 214
General directory 189
General directory - Pictogram view 192
General directory: -Text view 190
General Functions 43
General parameters 186
General path 201
Geometry 160
Global edit 153
Global edit filter 156
Grid 50
Grid filling 96
Grid filling parameters 176

—H—

Head selection 104
Head spacing 36

Help for EPCwin 10
 Help line parameter 49
 Help tools 48

—I—

Imaging 208
 Input / Output 193
 Introduction 10

—L—

Language / Default setting 221
 Link 210
 Load block - Save block 188

—M—

Main menu 25
 Main menu with design open 27
 Main menu without design open 26
 Manual punching 107
 Manual stitches 108
 Maximum stitch length 114
 Measuring 52
 Monogram fonts 21
 Monogram special characters 22
 Monogram TrueType fonts 166
 Multiple selection with polygon 129
 Multiple selection with rectangle 128

—N—

Needle designs 103
 Needle-color assignment 43
 Numerical change 151

—P—

Parameter Program Chain up objects 76
 Parameter Program Complex Stepstitch Fill 63
 Parameter Program Cross boll 74
 Parameter Program Cross stitch 70
 Parameter Program Curved Stepstitch Fill 68
 Parameter Program Definable Stitch-sequences 63
 Parameter Program Irregular divided satin stitch 58
 Parameter Program Monogram character 80
 Parameter Program Monogramming 78
 Parameter Program Object in Areas 71
 Parameter Program Object on circle 77
 Parameter Program Percentual Satin stitch 59
 Parameter Program Satin stitch 54
 Parameter Program Step-Lines 72
 Parameter Program Systematical divided Satin stitch 60
 Parameter Program Variable Satin stitch 60
 Parameter Rand 169
 Parameter Rapport 183
 Parameter Schneidloch 181
 Parameter set 54
 Parameter settings 53

Parameter Stich sequence 85
 Parameter Stoffhöhl 175
 Parameter True-Type Monogramm 184
 Parameter Wabenhöhl 174
 Parameter Wickellinie 185
 Parameter Ziegelhöhl 175
 Parameter Zughöhl 171
 Parameter Zugstäffel 170
 Parametersatz Design 85
 Polygon 163
 Printing 211
 Program selection 115
 Programmierung Sonderfunktionsanzeige 106
 Punching 107

—R—

Rectangle 163
 Rectangle (Angle) 164
 Rectangle (R) 164
 Rectangle (R) (Angle) 165
 Rectangle bored hole 99
 Rectangle bored hole parameters 180
 Reference data input 115
 Reference data Program Chain up objects 123
 Reference data Program Cross Boll 123
 Reference data Program Cross Stitch 121
 Reference data Program Curved Stepstitch Fill 121
 Reference data Program Monogramming 123
 Reference data Program Objects on circle 123
 Reference data Program Satin stitch 117
 Reference data Program Step-Lines 122
 Reference data Program Stepstitch Fill 119
 Remarks 51
 Remarks parameters 52
 Repeat view 47
 Response at functions 195

—S—

Scanner 207
 Schiffli design statistics 31
 Schneidloch 101
 Scrolling 43
 Select active design 30
 Select in block list 129
 Selection / Default setting 218
 Selection manager needle design/standard text/head selection 102
 Set Markings 114
 Shift block (drag & drop) 158
 Shortcut keys for EPCwin 18
 Single action 133
 Single selection 127
 Single-click selection 128
 Sonderfunktionen 108
 Sonderfunktionen Multi-Head 109
 Sonderfunktionen Schiffli 112
 Sonstige Automatikzeichenprogramme 182
 Spiral 165
 Spread 149
 Stencil 83
 Steplinie 102
 Stitch direction marker 160
 Stitch direction parameters 123
 Stitch distance ramps 82

Stitch sequence 84
Stoffhöhle 95
Suchen und Ersetzen Sonderfunktion 152
System check 228
System paths / Default setting 220

—T—

Terms and background information 11
Textbaustein 106
Tool box 147
Transfer EPCunix data 196
Transfer system parameters from EPCunix to
EPCwin 227
Type of selection 126

—U—

Utilities 213

—V—

Vector data (CMX) 202
Vector data (DXF) 203
View 44

—W—

Wabenhöhle 93
Work mode / Default setting 222

—Z—

Zeichenprogramm Stichlagen 182
Zeichnen Automatikprogramme 168
Ziegelhöhle 94
Zoom 44
Zugeffekte 168
Zughöhle 91
Zugstäffel 89

